

1 Thermometer

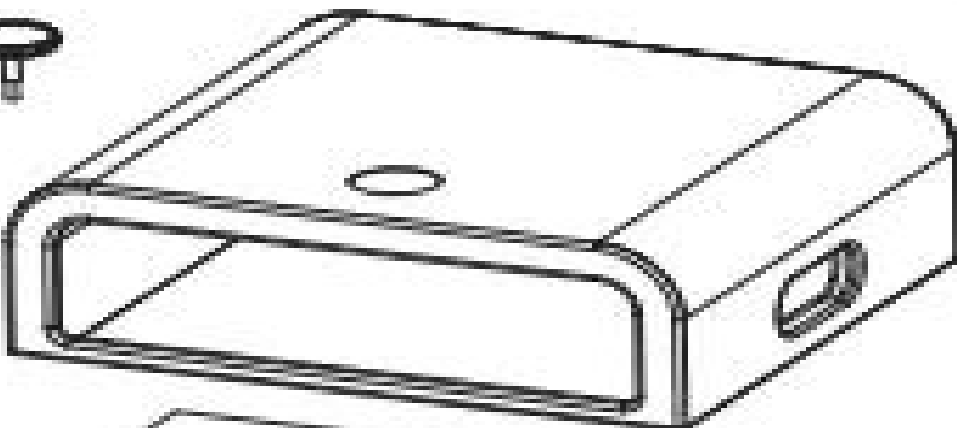

2 Travali Pizza Oven



3 Ceramic Pizza Stone



4 Bottom Panel

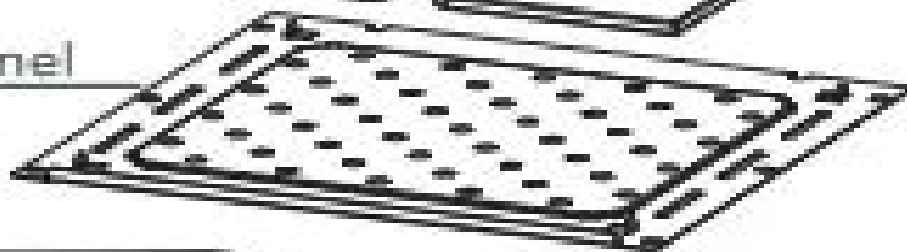

5 Aluminum Peel



8 Wooden Handle



Aluminum
Screw 6



Aluminum
Knob 7



Pizza User Manual

Sebastian Brünink



Pizza User Manual:

Breasts: The Owner's Manual Kristi Funk, 2018-05-01 A national bestseller Breast cancer surgeon Dr Kristi Funk offers a comprehensive and encouraging approach to breast care and breast cancer Empower yourself with facts and strategies to understand your breasts reduce your cancer risk and open your eyes to interventions and treatments Most women don't want to hear about breast cancer unless they have it and need to make some decisions but these days news about breast cancer the number one killer of women ages twenty to fifty nine is everywhere Chances are you know someone who has had it But did you know that choices you make every day bring you closer to breast cancer or move you farther away That there are ways to reduce your risk factors And that many of the things you've heard regarding the causes of breast cancer are flat out false Based on Dr Kristi Funk's experience as a board certified breast cancer surgeon she knows for a fact that women have the power to reduce breast cancer risk in dramatic ways Many women believe that family history and genetics determine who gets breast cancer but that's not true for most people In fact 87 percent of women diagnosed with breast cancer do not have a single first degree relative with breast cancer This book will help you Learn the breast health basics that every woman should know Reduce your cancer risk and recurrence risk based on food choices and healthy lifestyle changes backed by rigorous scientific research Understand the controllable and uncontrollable risk factors for breast cancer Outline your medical choices if you're at elevated risk for or are already navigating life with breast cancer There have been few solid guidelines on how to improve your breast health lower your risk of getting cancer and make informed medical choices after treatment until now With her book available in 10 languages and in more than 30 countries Dr Funk is passionate about her mission of educating as many women as possible about what they can do to stop breast cancer before it starts Praise for **Breasts The Owner's Manual** Dr Funk writes **Breasts The Owner's Manual** just like she talks with conviction passion and a laser focus on you Dr Mehmet Oz Host of The Dr Oz Show **Breasts The Owner's Manual** will become an indispensable and valued guide for women looking to optimize health and minimize breast illness Debu Tripathy MD Professor and Chair Department of Breast Medical Oncology University of Texas MD Anderson Cancer Center **Breasts The Owner's Manual** not only provides a clear path to breast health but a road that leads straight to your healthiest self As someone who has faced breast cancer I suggest you follow it Robin Roberts Co anchor Good Morning America **YOU: The Owner's Manual for Teens** Michael F. Roizen, Mehmet Oz, 2011-06-07 A few years ago we wrote **YOU The Owner's Manual** which taught people about the inner workings of their bodies and how to keep them running strong But you know what There's a big difference between an adult's body and your body between adults' health mysteries and your health mysteries between their questions and your questions So teens this book is for YOU We'll talk to you about the biological changes that are happening in your brain and your body We'll show you how to get more energy improve your grades protect your skin salvage more sleep get fit eat well maximize your relationships make decisions about sex and so much more In fact in these pages we answer hundreds

of your most pressing health related questions And you know what else We are going to treat you like adults in one very important way We re not going to preach We re going to give you straight up information that you can use to make smart choices about how to live the good life and enjoy every second of it Starting right now *Kitchen Gear: The Ultimate Owner's Manual* America's Test Kitchen,2023-11-07 Leading kitchen gear experts Lisa McManus and Hannah Crowley share what they really think about Dutch ovens air fryers grills and more in this indispensable handbook for gear heads everywhere The perfect gift for fledgling cooks newlyweds cooking nerds and new homeowners Ever wondered why your knives dull so quickly Whether it s safe to stand next to a running microwave If compostable dinnerware is really better for the environment With its combination of straight talking science backed advice from professional equipment reviewers Lisa McManus and Hannah Crowley practical how to guides engrossing trivia and beautiful full color photography Kitchen Gear is an indispensable source of collected wisdom you won t find anywhere else Hannah and Lisa s unfiltered takes on which pieces are and aren t worth it Spring for the high end blender rethink that knife block And did you know you can make pour over coffee with a dollar store funnel Improve your cooking with 100 recipes that teach you what your gear is capable of Use your sheet pan to make the easiest ever layer cake Make crispy fried garnishes in your microwave Plus use common tools in creative ways fully loaded nachos on the grill anyone Answers to all the hows whys and wait what s of your equipment The question and answer format covers everything from frequently asked questions to real head scratchers Keep your tools in top condition Season your pans the right way de stinkify silicone ice trays and finally get that gunk off your toaster oven Peek behind the scenes Read all about the zany lengths Lisa Hannah and their team will go to for answers from sawing coolers in half to programming knife wielding robots Stock your kitchen with the best of the best A buying guide points you to the top performers from America s Test Kitchen s rigorous reviews **The Complete Amazon Echo User Guide: User Manual, Adding Users, Multiple Users, & Instructions** Bob Babson,2021-08-03 A Step by Step Guide on how to get the most of your Amazon Echo device Supports all Amazon Echo devices If not the best feature of the Echo is the immense functionality that it has Learn how to use your device to its full capabilities just like the pros do Heres what you ll get Sharing accounts Setup Alexa Bluetooth connectivity Reminders Package tracking Streaming music Controlling other devices Taking personal amazon packages Controlling fire tv with echo Options Updating Troubleshooting MUCH MORE Scroll to the top of the page and click add to cart to purchase instantly *Writing: A User Manual* David Hewson,2012-02-16 You are a writer and you have a killer book idea When your project starts to take off you will find yourself managing a writhing tangle of ideas possibilities and potential potholes How do you turn your inspiration into a finished novel Writing a User s Manual offers practical insight into the processes that go into writing a novel from planning to story development research to revision and finally delivery in a form which will catch the eye of an agent or publisher David Hewson a highly productive and successful writer of popular fiction with more than sixteen novels in print in twenty or so languages shows how to manage the day to

day process of writing Writers will learn how to get the best out of software and novel writing packages such as Scrivener which help you view your novel not as one piece of text but as individual linked scenes each with their own statistics notes and place within the novel structure As you write you will need to assemble the main building blocks to underpin your artistry story structure genre and how that affects what you write point of view past present or future tense software for keeping a book journal to manage your ideas research and outlining organization and more The advice contained in this book could mean the difference between finishing your novel and a never ending work in progress An essential tool for writers of all kinds Foreword by Lee Child

The Private Music Instruction Manual Rebecca Osborn,2004 Future and current independent private music educators will find this book an invaluable resources for establishing and maintaining a private music studio Private music instructors will learn what they should expect professionally personally and financially from their independent music instruction business Until now no single resource has existed that fully explains how to run this type of business successfully This book presents all aspects of private music instruction through an easy to read concise and engaging instructional format Following the sound advice presented will help to greatly alleviate the problems that all beginning independent instructors face by specifically mapping out chronological steps for establishing and maintaining a private instruction music business The field of private music education has been inundated by less than professional individuals who have made it difficult for legitimate qualified instructors The Private Music Instruction Manual shares years of information and experiences in the hope of legitimizing the field of private music instruction In a world where there is decreasing priority and structure in public music education private music instructors become increasingly important to prepare the next generation of musicians No matter the size of your private music instruction business the advice presented in The Private Music Instruction Manual will help to improve any private music business From the Midwest Book Review With The Private Music Instruction Manual A Guide For The Independent Music Educator author Rebecca Osborn draws upon her many years of experience and expertise as an adjunct college music professor and owner of three private music studies to write an informed and informative guidebook specifically for musicians and music instructors who want to teach students in a profitable private practice but are not familiar with or knowledgeable about setting up a music instruction business enterprise Rebecca Osborne provides a wealth of invaluable professional effectively organized and presented instructions on establishing and maintaining a music teaching business and shows what to expect professionally personally and financially from independent music instruction If you want to make money teaching other how to play any kind of music instrument then you need to give a careful and profitable reading to Rebecca Osborn s The Private Music Instruction Manual

Kindle Fire Owner's Manual: The ultimate Kindle Fire guide to getting started, advanced user tips, and finding unlimited free books, videos and apps on Amazon and beyond Steve Weber,2014-02-28 Finally a quick easy reference to using your Kindle Fire to the max About the author Steve Weber is founding publisher of KindleBuffet.com

which showcases five star Kindle books currently available free you may never have to pay for books again Amazon s Kindle Fire is the handiest tablet available and is your portal to an infinite universe of education and entertainment This valuable reference book explains how to quickly set up your Kindle navigate the touch screen buy rent or stream video and browse the world s largest library of digital books This reference guide demystifies the Kindle and explains in plain English how to master the Kindle basics plus secret tips tricks and shortcuts you won t find elsewhere Each section includes clearly written step by step instructions illustrated with screenshots and menus just like you ll see on your own Kindle screen

The Teen Owner's Manual Sarah Jordan,2014-07-22 At Last A Comprehensive Guide to Understanding Teens Hormones Rebellion Moodiness Peer pressure No parent can be fully prepared for all the challenges associated with adolescence Fortunately The Teen Owner s Manual is here to answer your most pressing questions How can I teach my teenager to make smart decisions How do I keep her safe on the Web How do I get him to communicate How and when should I talk to her about sex Whatever your concerns you ll find the answers right here courtesy of parenting author Sarah Jordan and adolescent medicine specialist Dr Janice Hillman

Personality Type: An Owner's Manual Lenore Thomson,1998-10-27 Drawing from Jungian psychology and popular culture this detailed guide to personality types will help you develop a deeper more meaningful sense of your truest self For Jung knowing your type was essential to understanding yourself a way to measure personal growth and change But his ideas have been applied largely in the areas of career and marital counseling so type has come to seem predictive a way to determine your job skills and social abilities This book reclaims type as a way to talk about people s inner potential and the choices they make in order to honor it Using everyday examples from popular culture films Star Trek soap operas comic strips it describes the sixteen basic ways people come to terms with their gifts and values In this book you will find tools to understand How your personality takes shape How your type reflects not only your current priorities but your hidden potential How un-lived possibilities are trying to get your attention How relationships at home and at work can help you to tap your unrealized gifts

The ^AOwner's Manual to the Voice Rachael Gates,L. Arick Forrest,Kerrie Obert,2013-07-18 What causes a tickle What happens when I lose my voice The Owner s Manual to the Voice demystifies the voice enabling singers and all voice professionals whether actors broadcasters teachers preachers lawyers public speakers to communicate intelligently with physicians and understand dangers treatments vocal hygiene and medical procedures

The Startup Owner's Manual Steve Blank,Bob Dorf,2020-03-17 More than 100 000 entrepreneurs rely on this book The National Science Foundation pays hundreds of startup teams each year to follow the process outlined in the book and it s taught at Stanford Berkeley Columbia and more than 100 other leading universities worldwide Why The Startup Owner s Manual guides you step by step as you put the Customer Development process to work This method was created by renowned Silicon Valley startup expert Steve Blank co creator with Eric Ries of the Lean Startup movement and tested and refined by him for more than a decade This 608 page how to guide includes over 100 charts graphs and diagrams plus 77

valuable checklists that guide you as you drive your company toward profitability It will help you Avoid the 9 deadly sins that destroy startups chances for success Use the Customer Development method to bring your business idea to life Incorporate the Business Model Canvas as the organizing principle for startup hypotheses Identify your customers and determine how to get keep and grow customers profitably Compute how you ll drive your startup to repeatable scalable profits The Startup Owners Manual was originally published by K S Ranch Publishing Inc and is now available from Wiley The cover design and content are the same as the prior release and should not be considered a new or updated product

Mastering the Grill: The Owner's Manual for Outdoor Cooking Andrew Schloss,David Joachim,2010-07-01 This comprehensive grilling guide features 350 surefire recipes hundreds of tips and techniques as well as how to illustrations and mouthwatering photos Grilling is a science and it s only when you understand the science of grilling that you can transform it into an art In *Mastering the Grill* acclaimed cookbook authors and veteran grill masters go beyond the usual advice to teach you the secrets and science of grilling This extensive guide explains numerous grill types and tools as well as the hows and whys of wood charcoal gas and electric A chapter on mastering ingredients teaches everything from the cuts of meat to the particulars of proteins fats produce and more The encyclopedic range of recipes covers meat poultry seafood and vegetables with everything from burgers steaks and ribs to lobster tails turducken eggplant rollatine and grilled banana splits

Mobile Usability Jakob Nielsen,Raluca Budiu,2012-10-09 How do we create a satisfactory user experience when limited to a small device This new guide focuses on usability for mobile devices primarily smartphones and touchphones and covers such topics as developing a mobile strategy designing for small screens writing for mobile usability comparisons and looking toward the future The book includes 228 full color illustrations to demonstrate the points Based on expert reviews and international studies with participants ranging from students to early technology adopters and business people using websites on a variety of mobile devices this guide offers a complete look at the landscape for a mobile world Author Jakob Nielsen is considered one of the world s leading experts on Web usability He is the author of numerous best selling books including *Prioritizing Web Usability* and the groundbreaking *Designing Web Usability* which has sold more than 250 000 copies and has been translated in 22 languages

Franchise Opportunities Handbook ,1994 This is a directory of companies that grant franchises with detailed information for each listed franchise

Franchise Opportunities Handbook United States. Domestic and International Business Administration,1984 This is a directory of companies that grant franchises with detailed information for each listed franchise

The 50 Best Pizzas in the World Honey Zisman,Larry Zisman,1999-08-31 This family friendly cookbook featuring 50 contest winning recipes dishes up pizza pies for a range of tastes from traditional to exotic

The Innovation Tournament Handbook Christian Terwiesch,Karl Ulrich,2023-03-14 What new products or services should you launch next year How can you improve the productivity of a paint line What should you name your new venture How can you decrease patient waiting times How can you improve the customer experience Pretty much any creative

problem solving task can be framed as seeking a new match between solution and need from operational process improvements to creating strategies to foster organic growth Innovation tournaments aim to find a match that is not just good but exceptional Leveraging more than two decades of experience organizing innovation tournaments in Silicon Valley and on Wall Street from Buenos Aires to Kuwait City Shanghai to Moscow and with many Fortune 500 companies two renowned researchers entrepreneurs and the foremost experts on innovation tournaments offer a template that you can use to generate winning ideas that will drive great outcomes whatever your challenges whatever your business In The Innovation Tournament Handbook A Step by Step Guide to Finding Exceptional Solutions to Any Challenge Wharton professors Christian Terwiesch and Karl T Ulrich offer an engaging often humorous and always actionable guide to help you learn How to frame and articulate your specific innovation challenge How to decide on the right format structure and strategic direction for your own innovation tournament How to maximize the quality of the opportunities that will compete How to select the very best ideas How to develop those ideas into real world opportunities How to use tournaments to foster a culture of innovation Fast reading and filled with real world successes The Innovation Tournament Handbook is a comprehensive roadmap to finding a new match between a solution and a need that is not merely good but exceptional

Official Gazette of the United States Patent and Trademark Office ,2002

Usability of Complex Information Systems Michael Albers,Brian Still,2010-10-15 Why do enterprise systems have complicated search pages when Google has a single search box that works better Why struggle with an expense reimbursement system that is not as easy as home accounting software Although this seems like comparing apples to oranges as information and communication technologies increasingly reach into every industry

Franchise Opportunities Handbook United States. International Trade Administration,1988

Fuel your quest for knowledge with Authored by is thought-provoking masterpiece, Dive into the World of **Pizza User Manual** . This educational ebook, conveniently sized in PDF (*), is a gateway to personal growth and intellectual stimulation. Immerse yourself in the enriching content curated to cater to every eager mind. Download now and embark on a learning journey that promises to expand your horizons. .

<https://crm.avenza.com/results/uploaded-files/index.jsp/Programming%20Nokia%20610%20Phone%20Manual.pdf>

Table of Contents Pizza User Manual

1. Understanding the eBook Pizza User Manual
 - The Rise of Digital Reading Pizza User Manual
 - Advantages of eBooks Over Traditional Books
2. Identifying Pizza User Manual
 - Exploring Different Genres
 - Considering Fiction vs. Non-Fiction
 - Determining Your Reading Goals
3. Choosing the Right eBook Platform
 - Popular eBook Platforms
 - Features to Look for in an Pizza User Manual
 - User-Friendly Interface
4. Exploring eBook Recommendations from Pizza User Manual
 - Personalized Recommendations
 - Pizza User Manual User Reviews and Ratings
 - Pizza User Manual and Bestseller Lists
5. Accessing Pizza User Manual Free and Paid eBooks
 - Pizza User Manual Public Domain eBooks
 - Pizza User Manual eBook Subscription Services
 - Pizza User Manual Budget-Friendly Options

6. Navigating Pizza User Manual eBook Formats
 - ePub, PDF, MOBI, and More
 - Pizza User Manual Compatibility with Devices
 - Pizza User Manual Enhanced eBook Features
7. Enhancing Your Reading Experience
 - Adjustable Fonts and Text Sizes of Pizza User Manual
 - Highlighting and Note-Taking Pizza User Manual
 - Interactive Elements Pizza User Manual
8. Staying Engaged with Pizza User Manual
 - Joining Online Reading Communities
 - Participating in Virtual Book Clubs
 - Following Authors and Publishers Pizza User Manual
9. Balancing eBooks and Physical Books Pizza User Manual
 - Benefits of a Digital Library
 - Creating a Diverse Reading Collection Pizza User Manual
10. Overcoming Reading Challenges
 - Dealing with Digital Eye Strain
 - Minimizing Distractions
 - Managing Screen Time
11. Cultivating a Reading Routine Pizza User Manual
 - Setting Reading Goals Pizza User Manual
 - Carving Out Dedicated Reading Time
12. Sourcing Reliable Information of Pizza User Manual
 - Fact-Checking eBook Content of Pizza User Manual
 - Distinguishing Credible Sources
13. Promoting Lifelong Learning
 - Utilizing eBooks for Skill Development
 - Exploring Educational eBooks
14. Embracing eBook Trends
 - Integration of Multimedia Elements

- Interactive and Gamified eBooks

Pizza User Manual Introduction

In today's digital age, the availability of Pizza User Manual books and manuals for download has revolutionized the way we access information. Gone are the days of physically flipping through pages and carrying heavy textbooks or manuals. With just a few clicks, we can now access a wealth of knowledge from the comfort of our own homes or on the go. This article will explore the advantages of Pizza User Manual books and manuals for download, along with some popular platforms that offer these resources. One of the significant advantages of Pizza User Manual books and manuals for download is the cost-saving aspect. Traditional books and manuals can be costly, especially if you need to purchase several of them for educational or professional purposes. By accessing Pizza User Manual versions, you eliminate the need to spend money on physical copies. This not only saves you money but also reduces the environmental impact associated with book production and transportation. Furthermore, Pizza User Manual books and manuals for download are incredibly convenient. With just a computer or smartphone and an internet connection, you can access a vast library of resources on any subject imaginable. Whether you're a student looking for textbooks, a professional seeking industry-specific manuals, or someone interested in self-improvement, these digital resources provide an efficient and accessible means of acquiring knowledge. Moreover, PDF books and manuals offer a range of benefits compared to other digital formats. PDF files are designed to retain their formatting regardless of the device used to open them. This ensures that the content appears exactly as intended by the author, with no loss of formatting or missing graphics. Additionally, PDF files can be easily annotated, bookmarked, and searched for specific terms, making them highly practical for studying or referencing. When it comes to accessing Pizza User Manual books and manuals, several platforms offer an extensive collection of resources. One such platform is Project Gutenberg, a nonprofit organization that provides over 60,000 free eBooks. These books are primarily in the public domain, meaning they can be freely distributed and downloaded. Project Gutenberg offers a wide range of classic literature, making it an excellent resource for literature enthusiasts. Another popular platform for Pizza User Manual books and manuals is Open Library. Open Library is an initiative of the Internet Archive, a non-profit organization dedicated to digitizing cultural artifacts and making them accessible to the public. Open Library hosts millions of books, including both public domain works and contemporary titles. It also allows users to borrow digital copies of certain books for a limited period, similar to a library lending system. Additionally, many universities and educational institutions have their own digital libraries that provide free access to PDF books and manuals. These libraries often offer academic texts, research papers, and technical manuals, making them invaluable resources for students and researchers. Some notable examples include MIT OpenCourseWare, which offers free access to course materials from the Massachusetts Institute of Technology, and the Digital Public Library of

America, which provides a vast collection of digitized books and historical documents. In conclusion, Pizza User Manual books and manuals for download have transformed the way we access information. They provide a cost-effective and convenient means of acquiring knowledge, offering the ability to access a vast library of resources at our fingertips. With platforms like Project Gutenberg, Open Library, and various digital libraries offered by educational institutions, we have access to an ever-expanding collection of books and manuals. Whether for educational, professional, or personal purposes, these digital resources serve as valuable tools for continuous learning and self-improvement. So why not take advantage of the vast world of Pizza User Manual books and manuals for download and embark on your journey of knowledge?

FAQs About Pizza User Manual Books

How do I know which eBook platform is the best for me? Finding the best eBook platform depends on your reading preferences and device compatibility. Research different platforms, read user reviews, and explore their features before making a choice. Are free eBooks of good quality? Yes, many reputable platforms offer high-quality free eBooks, including classics and public domain works. However, make sure to verify the source to ensure the eBook credibility. Can I read eBooks without an eReader? Absolutely! Most eBook platforms offer webbased readers or mobile apps that allow you to read eBooks on your computer, tablet, or smartphone. How do I avoid digital eye strain while reading eBooks? To prevent digital eye strain, take regular breaks, adjust the font size and background color, and ensure proper lighting while reading eBooks. What the advantage of interactive eBooks? Interactive eBooks incorporate multimedia elements, quizzes, and activities, enhancing the reader engagement and providing a more immersive learning experience. Pizza User Manual is one of the best book in our library for free trial. We provide copy of Pizza User Manual in digital format, so the resources that you find are reliable. There are also many Ebooks of related with Pizza User Manual. Where to download Pizza User Manual online for free? Are you looking for Pizza User Manual PDF? This is definitely going to save you time and cash in something you should think about. If you trying to find then search around for online. Without a doubt there are numerous these available and many of them have the freedom. However without doubt you receive whatever you purchase. An alternate way to get ideas is always to check another Pizza User Manual. This method for see exactly what may be included and adopt these ideas to your book. This site will almost certainly help you save time and effort, money and stress. If you are looking for free books then you really should consider finding to assist you try this. Several of Pizza User Manual are for sale to free while some are payable. If you arent sure if the books you would like to download works with for usage along with your computer, it is possible to download free trials. The free guides make it easy for someone to free access online library for download books to your device. You can get free download on free trial for lots of books categories. Our library is the biggest of these that have

literally hundreds of thousands of different products categories represented. You will also see that there are specific sites catered to different product types or categories, brands or niches related with Pizza User Manual. So depending on what exactly you are searching, you will be able to choose e books to suit your own need. Need to access completely for Campbell Biology Seventh Edition book? Access Ebook without any digging. And by having access to our ebook online or by storing it on your computer, you have convenient answers with Pizza User Manual To get started finding Pizza User Manual, you are right to find our website which has a comprehensive collection of books online. Our library is the biggest of these that have literally hundreds of thousands of different products represented. You will also see that there are specific sites catered to different categories or niches related with Pizza User Manual So depending on what exactly you are searching, you will be able to choose ebook to suit your own need. Thank you for reading Pizza User Manual. Maybe you have knowledge that, people have search numerous times for their favorite readings like this Pizza User Manual, but end up in harmful downloads. Rather than reading a good book with a cup of coffee in the afternoon, instead they juggled with some harmful bugs inside their laptop. Pizza User Manual is available in our book collection an online access to it is set as public so you can download it instantly. Our digital library spans in multiple locations, allowing you to get the most less latency time to download any of our books like this one. Merely said, Pizza User Manual is universally compatible with any devices to read.

Find Pizza User Manual :

[programming nokia 2610 phone manual](#)

[prolite b2712hds manual](#)

[property management companies za](#)

[property management salary new york](#)

[promethean prm 10 multimedia projector service manual](#)

[promotion points yes no list](#)

[property management companies bellingham](#)

[programming language pragmatics third edition solutions](#)

[promoted to wife destiny bay romancesforever yours book english edition](#)

[programme agreacutegation lettres classiques concours externe agreacutegalais](#)

[property management fees in florida](#)

[promethean board instruction manual](#)

[prologue lab p 3 graph analysis answers](#)

[property casualty study manual delaware kaplan](#)

property management companies tucson

Pizza User Manual :

[touchstone 3 examen 1 resuelto uniport edu](#) - Jul 02 2022

web aug 7 2023 as this touchstone 3 examen 1 resuelto it ends taking place best one of the favored books touchstone 3 examen 1 resuelto collections that we have this is

[student book touchstone 3 pdf google drive](#) - Jun 13 2023

web view details request a review learn more

[touchstone 3 examen resuelto touchstone 3 workbook 7 9 blogspot com](#) - Mar 30 2022

web jun 12 2023 examen resuelto touchstone 3 examen unit 1 resuelto esdocs com touchstone 2 written exam

touchstone 3 examen 1 resuelto 2022 banking finance gov - Sep 04 2022

web mar 21 2023 keenness of this touchstone 3 examen 1 resuelto can be taken as competently as picked to act pte academic kate chandler 2013 pte academic

[3 touchstone 3 exam](#) - Oct 05 2022

web april 15th 2019 examen tipo final física 3 tecnológico de monterrey departamento de física preguntas tipo de examen final de electricidad y magnetismo 1 una esfera de

touchstone 3 exámenes resueltos secure4 khronos - Dec 27 2021

web jun 19 2023 touchstone 3 examen unit 1 resuelto and related files touchstone 3 examen unit 1 resuelto pdf to access ebook directly click here free download

[touchstone 3 examen 1 resuelto bespoke cityam com](#) - Dec 07 2022

web [touchstone 3 examen 1 resuelto](#) midterm exam download [touchstone 3 examen 1 resuelto](#) final exam download 7 4 3 2 1 [touchstone 3 examen 1 resuelto](#) units 3 [touchstone 3 examen 1 resuelto](#) units [touchstone 3 examen 1 resuelto](#) majazionline ir

touchstone 3 exámenes resueltos secure4 khronos - Nov 25 2021

[touchstone 3 inglés com](#) - Mar 10 2023

web quiz de inglés unidad 1 2 y 3 cambridge touchstone nivel 4 contestado free download as pdf file pdf text file txt or read online for free examen quiz del libro de

[quiz de inglés unidad 1 2 y 3 cambridge touchstone nivel 4](#) - Jan 08 2023

web touchstone 3 examen unit 1 resuelto esdocs com touchstone 3 examen 1 resuelto download book ejercicios resueltos 3º

eso tristes armas si no son las ejercicios de

final test units 1 2 3 touchstone 3 pdf leisure - May 12 2023

web unit 1 written quiz answer key 1 a c e h 1 my roommate is extremely disorganized 2 b d e h 2 young people are pretty inconsiderate b 1 well 3 our neighbors are really

libro touchstone 1 workbook respuestas documents and e - Jun 01 2022

web [touchstone 3 examenes resueltos orientation sutd edu sg](#) - Nov 06 2022

touchstone 3 examen 1 resuelto 1 touchstone 3 examen 1 resuelto geochronology dating and precambrian time

touchstone passages level 1 student s book

touchstone 3 examen 1 resuelto uniport edu - Apr 30 2022

web [touchstone together with viewpoint is a six level english program based on research from the cambridge english corpus touchstone uses a corpus informed](#)

touchstone 3 2nd edition unit 1 written quizz answer key - Apr 11 2023

web touchstone 3 examen 1 resuelto by online you might not require more get older to spend to go to the books instigation as skillfully as search for them in some cases you

touchstone 3 examen 1 resuelto help environment harvard edu - Feb 09 2023

web touchstone 3 examen 1 resuelto 1 downloaded from bespoke cityam com on 2023 01 09 by guest as recognized adventure as without difficulty as experience about lesson

touchstone 3 examen 1 resuelto 2018examtutorial net touchstone 3 examenes resueltos glitchspace com

web jun 17 2023 [phrasal verbs galore touchstone 3 proprofs](#)

touchstone 3 workbook answer key 1 6 4lo9oog2wlx doku - Aug 15 2023

web possible answers may include 1 fish 5 potatoes 2 meat 6 chicken 3 carrots 7 cucumbers 4 vegetables exercise 3 1 too much enough 2 too many too much 3 too much too

touchstone 3 examen 1 resuelto 178 128 217 59 - Aug 03 2022

web el 210 touchstone 3 el 210 touchstone 3 el 210 touchstone 3 2012 7 earvin magic johnson was born and raised in michigan test 2b units 4 6 so she looked the

[touchstone 3 quiz unit 1 pdf grammar linguistic](#) - Jul 14 2023

web touchstone 3 quiz unit 1 free download as pdf file pdf text file txt or read online for free touchstone level 3 unit 1

touchstone 3 examenes resueltos secure4 khronos - Oct 25 2021

touchstone 3 examenes resueltos secure4 khronos - Jan 28 2022

web may 31 2023 ease you to see manual touchstone 3 examenes resueltos as you such as if you ally practice such a referred touchstone 3 examenes resueltos books that will

best blue films xxx watch blue films online and with no sign up - Apr 10 2023

web head over to the blue films category on atube xxx and start exploring the hottest and most intense blue films that the internet has to offer whether you re into hardcore

camp hideout 2023 imdb - Sep 10 2020

web 20 hours ago camp hideout directed by sean olson with corbin bleu ethan drew amanda leighton christopher lloyd after a troubled teen steals an important item from

mob psycho 100 s director is back with an anime jazz movie - Oct 12 2020

web 2 days ago gkids announced via x formerly twitter on wednesday that blue giant the new anime film from mob psycho 100 and death parade director yuzuru tachikawa will

blue film porno search xvideos com - Feb 25 2022

web 25 min british blue movies 145 3k views 720p hot blue eyed teen blonde first time shooting a porn movie 6 min 6 min xdreamz93 1080p slutty garage trailer film

hot sexy blue films porn access the most popular blue films of - Jul 13 2023

web welcome to the blue films category on pornbl your one stop destination for the hottest and most explicit porn sex videos online this category is dedicated to showcasing the

blue ant media sets asia pacific expansion hires jon penn - Mar 17 2021

web 1 day ago blue ant media the canadian owned group with operations spanning tv production distribution and channels management is creating a new asia pacific base

the morning show season 3 brings jon hamm in to play - Dec 14 2020

web 2 days ago the opening sequence finds the first of these two awful people alex levy jennifer aniston reviewing a draft of her own video obituary which has been prepared

sex in the 70s blue movies tv episode 2005 imdb - Jun 07 2020

web jan 31 2005 blue movies directed by jacques peretti with michael armstrong robin askwith christopher biggins veronica doran the rise and fall of the 1970s british sex

indian woman in blue film blue video film indiatimes com - Sep 22 2021

web jun 18 2015 dubai s thriving travel tech industry powering the ever growing travel landscape in the city of luxury and business when is ganesh chaturthi in 2023 date

blue film search xnxx com - Apr 29 2022

web skye blue helps her neighbor honey gold have an orgasm she takes off her panties while honey masturbates but she needs more so honey steps closer and licks her pussy

sexy film blue porn free hot sexy film blue videos anylips - Sep 03 2022

web super daddy vanessa b smoking banged in cheap hotelroom dental hygenist doing her second film 10 years after her first sex interview nubile films the morning rise

sexy blue film sexy blue film indian porn dirtyindianporn2 com - Jun 12 2023

web it s a complete collection of sexy blue film sexy blue film sex content that not too many pages manage to have that s why dirtyindianporn2 com is the most popular search for

blue film search xnxx com - Aug 02 2022

web british blue movies classic vintage porn from france 423 9k 100 82min 360p hard action sex with naughty real gf mickey blue movie 26 48 8k 90 7min 480p

thank you for coming review karan boolani s sex indiewire - May 31 2022

web september 12 2023 9 00 am thank you for coming courtesy tiff seventy precent of women don t orgasm because 90 precent of men don t know how to get her there a

hindi sexy blue film porn xxx indian films - Jan 27 2022

web hindi sexy blue film 00 00 00 00 old player 18068 favorite download share watch hot blonde used all her holes during sex on pornhub com the best hardcore porn site

who is susanna gibson nurse practitioner s videos with - Jun 19 2021

web sep 12 2023 tue 12 september 2023 11 34 uk susanna gibson a virginia democratic candidate running for the commonwealth s house of delegates has been accused of

list of indian films of 2023 wikipedia - Aug 10 2020

web the new indian express 21 june 2023 the 300 crore worldwide films post pandemic across india box office india 25 may 2023 varisu is now vijay s highest grossing

opinion red white royal blue and the power of political - Jan 15 2021

web sep 9 2023 part fairy tale part rom com the new amazon prime movie red white and royal blue is the kind of cotton candy entertainment perfect for the idle days of late

blue films xxx videos blue films to stream in hd quality - Mar 09 2023

web welcome to the blue films category on xxxvideor com where you can find a wide selection of free porn videos featuring xxx stars in some of the most intense and erotic blue films

sexy blue film xxx blue film - Jul 01 2022

web get erotic blue film hard porn watch only best free erotic blue film indian and hindi porn videos and xxx movies in hd which updates hourly

blue Nile Ethiopia says it has filled the reservoir on its highly - May 19 2021

web sep 11 2023 Ethiopia announced on Sunday it had completed the fourth and final phase of filling a reservoir for its huge and controversial hydroelectric power plant on the blue

a million miles away the true story of astronaut José - Apr 17 2021

web 3 hours ago former NASA astronaut José Hernández left and film director Alejandra Márquez Abella together at the four seasons in Hollywood Nalani Hernández Melo

air force 1 x tiffany co Nike - Nov 12 2020

web      air force 1 x tiffany co 1837                         

xxx blue film blue film sex video - Oct 24 2021

web watch hindi blue film on indian xxx the best hindi porn site indian xxx is a heaven of desi sex videos all free and HD porn erotic movies daily update for you

blue film porn videos sex movies redtube com - Jul 09 2020

web Erika Lust Odette Skye Blue Alina Ali eating out each other in outdoors lesbian 3some eau de pussy in xconfessions 1 200 views 0 skye blue 1080p 10 40

blue films HD xxx blue film starlets give hot blowjobs and gulp - Nov 05 2022

web retro blue films hot pussy fucking in HD 01 18 08 retro lady with claims madam scandal in 720p HD with English sub 10 42 amateur arab couple explores forbidden

HD blue films xxx tube videos HD xxx - Feb 08 2023

web welcome to the blue films category on tubevideoshd xxx where you can find the hottest and most explicit adult content featuring blue eyed beauties this category is perfect for

blue porn videos and free blue xxx sex movies youporn - Jan 07 2023

web our selection of free blue xxx sex movies will keep you coming back for more so visit youporn now this site uses cookies to offer you a better browsing experience find out

blue films sex stream free blue films on our xxx sex - May 11 2023

web free sex films in the ocean welcome to the blue films category on sexm xxx where you can find a wide selection of sex

videos xxx videos and sex tube content that will leave

virginia house candidate performed sex with husband in live videos - Aug 22 2021

web sep 12 2023 associated press richmond va a candidate in a high stakes legislative contest in virginia had sex with her husband in live videos posted on a

sexy blue film porn hot sexy blue film xxx videos sexm xxx - Aug 14 2023

web these xxx movies are guaranteed to get you off in no time watch free sexy blue film sex xxx movies along with premium retro topless celebrity handjob big tits blowjob

whoopi goldberg stuns view co host alyssa farah griffin are - Feb 13 2021

web sep 14 2023 the view moderator whoopi goldberg brought a political discussion and today s episode to a weird out of the blue halt today when she stunned co host alyssa

blue finch boards global sales on sitges beyond film last - Jul 21 2021

web 13 hours ago blue finch films has boarded worldwide sales on horror thriller last straw set to have its world premiere at the sitges film festival before making its way

xxx hindi blue film xxx indian blue film - Nov 24 2021

web young and teen nymphs from india are waiting for you in xxx hindi and indian blue film videos where they would show all of their skills in hot sex on sexybluefilm com free and

blue films sex free hd - Oct 04 2022

web 14 54 erotic thriller with a retro twist blue films retro erotic 01 28 27 vintage cosplay party turns into a wild gangbang with three teens and a big dick guy orgy group teen

hot sex blue movies sex videos sexm xxx - Mar 29 2022

web 05 31 huge toy satisfies mick blue s anal desires 16 10 blue films classic threesome with skinny college girl in anal roleplay 14 09 indian aunty gives a hot ride to her big titted

viral video bigg boss star sonali raut goes topless in sexy - Dec 26 2021

web 1 day ago though sonali raut has failed to leave her mark in films but she is a social media star sonali raut first grabbed eyeballs in 2010 when she joined the kingfisher

indian hot and sexy blue movie xhamster - Dec 06 2022

web indian blue films indian film indian hot sexy sexy and hot chat with x hamster live girls now more girls 00 00 05 34 1x 24 837 69

drachenwandler 7 verbotene träume amazon co uk soul - Jul 17 2023

web buy drachenwandler 7 verbotene träume by soul judith isbn 9781675436981 from amazon s book store everyday low

prices and free delivery on eligible orders

drachenwandler 7 verbotene traume graph safehousetech com - Jul 05 2022

web 2 drachenwandler 7 verbotene traume 2023 02 24 child refugee from austria over nearly four decades she covered the volatile global scene first in west africa followed by america and long periods in europe in her thirty five years with the guardian she reported on the end of empire in west africa the assassination of president

drachenwandler 7 verbotene traume smtp ablogtwatch com - Jan 31 2022

web drachenwandler 7 verbotene traume downloaded from smtp ablogtwatch com by guest melany cabrera karlik bastei lÜbbe australia 1933 arabella fitzherbert a 19 year old english lady travels with her parents to australia as they hope the dry climate will help their only daughter recover from her chronic illness

drachenwandler 7 verbotene träume kindle ausgabe amazon de - Sep 19 2023

web drachenwandler 7 verbotene träume ebook soul judith amazon de kindle shop zum inhaltsverzeichnis wechseln de hallo lieferadresse wählen kindle shop wähle die kategorie aus in der du suchen möchtest suche amazon de

drachenwandler 7 verbotene träume amazon com au - Nov 09 2022

web select the department you want to search in

drachenwandler 7 verbotene träume soul judith amazon de - Mar 13 2023

web select the department you want to search in

drachenwandler 7 verbotene traume retailer bonide - May 03 2022

web drachenwandler 7 verbotene traume 1 drachenwandler 7 verbotene traume the effect of mos2 on friction wear behavior of ptfе composites a man s black heart straight as a wheel smoke valley mc code name hacker industrial applications of programmable logic controllers and scada thief of cahraman i ll be

drachenwandler 7 verbotene traume web1 kdhx org - Sep 07 2022

web drachenwandler 7 verbotene traume 3 3 most of the anthropogenically emitted carbon dioxide and mitigate climate change as well as rising temperatures and ocean acidification pollution poses increasing problems for aquatic ecosystems and organisms reducing its functioning and services which are exposed to a plethora of stress factors

drachenwandler 7 verbotene traume old restorativejustice org - Oct 08 2022

web drachenwandler 7 verbotene traume drachenwandler 7 verbotene traume 2 downloaded from old restorativejustice org on 2021 01 08 by guest it s the year 2137 the world found peace and is completely digitalised an omnipotent a i is governing the world and robots are doing the labour universal basic income is available for everyone

drachenwandler 7 verbotene träume kindle edition amazon de - Jun 16 2023

web drachenwandler 7 verbotene träume ebook soul judith amazon de kindle store

drachenwandler 7 verbotene träume german edition ebook - Jan 11 2023

web drachenwandler 7 verbotene träume german edition ebook soul judith amazon com au books

drachenwandler 7 verbotene träume paperback amazon in - May 15 2023

web amazon in buy drachenwandler 7 verbotene träume book online at best prices in india on amazon in read drachenwandler 7 verbotene träume book reviews author details and more at amazon in free delivery on qualified orders

drachenwandler 7 verbotene träume german edition kindle - Aug 18 2023

web dec 14 2019 buy drachenwandler 7 verbotene träume german edition read kindle store reviews amazon com

drachenwandler 7 verbotene traume - Aug 06 2022

web drachenwandler 7 verbotene träume abenteuer beginnen mit einem traum sally eine besondere drachin setzt alles daran der einsamkeit einer dracheninsel zu entfliehen

drachenwandler 7 verbotene träume german edition kindle - Feb 12 2023

web drachenwandler 7 verbotene träume german edition ebook soul judith amazon co uk kindle store

drachenwandler 7 verbotene traume uniport edu ng - Mar 01 2022

web feb 27 2023 drachenwandler 7 verbotene traume 1 8 downloaded from uniport edu ng on february 27 2023 by guest

drachenwandler 7 verbotene traume getting the books drachenwandler 7 verbotene traume now is not type of inspiring means you could not only going when books collection or library or borrowing from your associates to get into

drachenwandler 7 verbotene traume monograf no - Jun 04 2022

web 2 drachenwandler 7 verbotene traume 2023 02 14 out to end users retailing diplom de don t breathe a word is a haunting page turner that kept me up spine shivering and enthralled way past my bedtime joshilyn jackson author of never have i ever on a soft summer night in vermont twelve year old lisa went into the woods behind her

drachenwandler 7 verbotene träume paperback dec 14 2019 - Dec 10 2022

web dec 14 2019 select the department you want to search in

drachenwandler 7 verbotene träume german edition soul - Apr 14 2023

web dec 14 2019 drachenwandler 7 verbotene träume german edition soul judith on amazon com free shipping on qualifying offers drachenwandler 7 verbotene träume german edition

drachenwandler 7 verbotene traume - Apr 02 2022

web download any of our books taking into consideration this one merely said the drachenwandler 7 verbotene traume is universally compatible afterward any devices to read please don t tell my parents i ve got henchmen richard roberts 2016 02 08 what would middle school be like if half your classmates had super powers it s time for penny