

2206D Engines

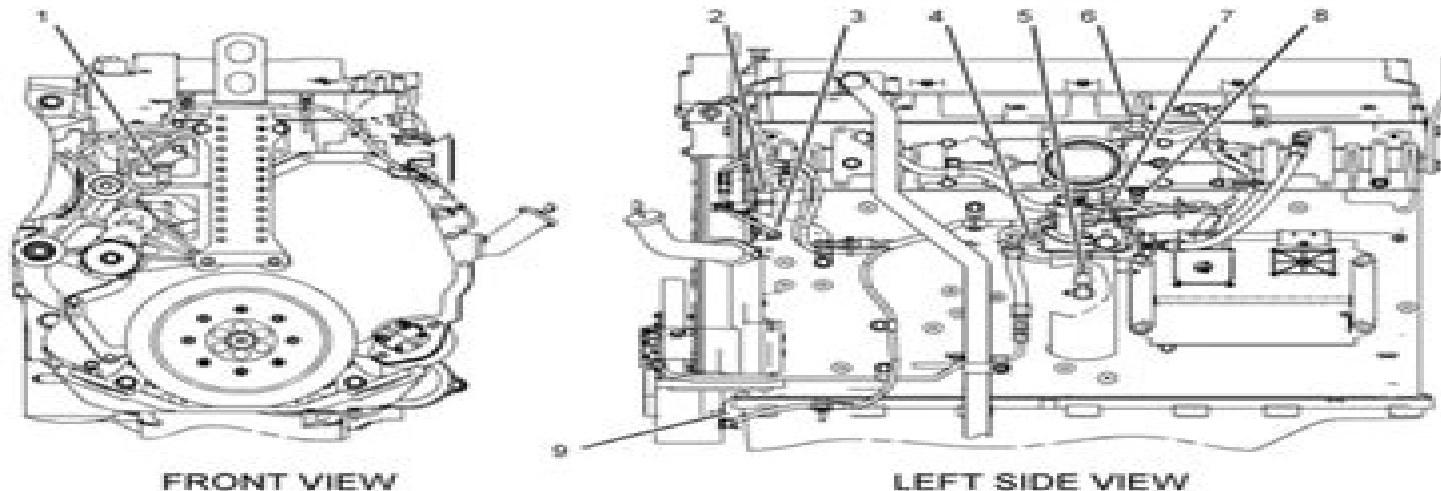

Illustration 5

g0109045

Locations of the sensors on 2206D engines

- | | | |
|--|--------------------------------|--|
| (1) Engine coolant temperature sensor | (4) Fuel pressure sensor | (7) Fuel temperature sensor |
| (2) Atmospheric pressure sensor | (5) Engine oil pressure sensor | (8) Intake manifold air temperature sensor |
| (3) Secondary engine speed/timing sensor | (6) Boost pressure sensor | (9) Primary engine speed/timing sensor |

i02957563

Diagnostic Capabilities

Diagnostic Codes

The engines Electronic Control Module (ECM) can monitor the circuitry between the ECM and the engines components. The ECM can also monitor the engines operating conditions. If the ECM detects a problem, a code is generated.

There are two categories of codes:

- Diagnostic code
- Event code

Diagnostic Code – A diagnostic code indicates an electrical problem such as a short circuit or an open circuit in the engines wiring or in an electrical component.

Event Code – An event code is generated by the detection of an abnormal engine operating condition. For example, an event code will be generated if the oil pressure is too low. In this case, the event code indicates the symptom of a problem. Generally, event codes indicate abnormal operating conditions or mechanical problems rather than electrical problems.

Codes can have two different states:

- Active
- Logged

Active Codes

An active code indicates that a problem is present. Service the active code first. For the appropriate troubleshooting procedure for a particular code, refer to the appropriate troubleshooting procedure.

Perkins Engine Model 2200 Workshop Manual

Ensheng Dong



Perkins Engine Model 2200 Workshop Manual:

Fleet Owner ,1988 *The Oil Engine Manual* ,1950 **The Road Way** ,1991 The Commercial Motor ,1980 *I & T Shop Service* ,1978 **The Modern Motor Engineer: Data sheets and wiring diagrams** Arthur William Judge,1957
Power Farming in Australia and New Zealand Technical Manual ,1975 **Farmers and Consumers Market Bulletin** ,2011 *Cruising World* ,1984-07 *Diesel Equipment Superintendent* ,1962 *Electrochemical and Metallurgical Industry* ,1961 **The Oil Engine and Gas Turbine** ,1961 **Scientific American** ,1882 Monthly magazine devoted to topics of general scientific interest *Motor Cycling and Motoring* ,1985 **Forest Industries Review** ,1970 **Diesel Power** ,1957 **Minnesota Cities** ,1985-04 **Paperbound Books in Print** ,1992 *The Southern Lumberman* ,1979
The British National Bibliography Arthur James Wells,1972

Fuel your quest for knowledge with Learn from is thought-provoking masterpiece, **Perkins Engine Model 2200 Workshop Manual** . This educational ebook, conveniently sized in PDF (Download in PDF: *), is a gateway to personal growth and intellectual stimulation. Immerse yourself in the enriching content curated to cater to every eager mind. Download now and embark on a learning journey that promises to expand your horizons. .

https://crm.avenza.com/About/Resources/Download_PDFS/polar%20watch%20manual.pdf

Table of Contents Perkins Engine Model 2200 Workshop Manual

1. Understanding the eBook Perkins Engine Model 2200 Workshop Manual
 - The Rise of Digital Reading Perkins Engine Model 2200 Workshop Manual
 - Advantages of eBooks Over Traditional Books
2. Identifying Perkins Engine Model 2200 Workshop Manual
 - Exploring Different Genres
 - Considering Fiction vs. Non-Fiction
 - Determining Your Reading Goals
3. Choosing the Right eBook Platform
 - Popular eBook Platforms
 - Features to Look for in an Perkins Engine Model 2200 Workshop Manual
 - User-Friendly Interface
4. Exploring eBook Recommendations from Perkins Engine Model 2200 Workshop Manual
 - Personalized Recommendations
 - Perkins Engine Model 2200 Workshop Manual User Reviews and Ratings
 - Perkins Engine Model 2200 Workshop Manual and Bestseller Lists
5. Accessing Perkins Engine Model 2200 Workshop Manual Free and Paid eBooks
 - Perkins Engine Model 2200 Workshop Manual Public Domain eBooks
 - Perkins Engine Model 2200 Workshop Manual eBook Subscription Services
 - Perkins Engine Model 2200 Workshop Manual Budget-Friendly Options

6. Navigating Perkins Engine Model 2200 Workshop Manual eBook Formats
 - ePub, PDF, MOBI, and More
 - Perkins Engine Model 2200 Workshop Manual Compatibility with Devices
 - Perkins Engine Model 2200 Workshop Manual Enhanced eBook Features
7. Enhancing Your Reading Experience
 - Adjustable Fonts and Text Sizes of Perkins Engine Model 2200 Workshop Manual
 - Highlighting and Note-Taking Perkins Engine Model 2200 Workshop Manual
 - Interactive Elements Perkins Engine Model 2200 Workshop Manual
8. Staying Engaged with Perkins Engine Model 2200 Workshop Manual
 - Joining Online Reading Communities
 - Participating in Virtual Book Clubs
 - Following Authors and Publishers Perkins Engine Model 2200 Workshop Manual
9. Balancing eBooks and Physical Books Perkins Engine Model 2200 Workshop Manual
 - Benefits of a Digital Library
 - Creating a Diverse Reading Collection Perkins Engine Model 2200 Workshop Manual
10. Overcoming Reading Challenges
 - Dealing with Digital Eye Strain
 - Minimizing Distractions
 - Managing Screen Time
11. Cultivating a Reading Routine Perkins Engine Model 2200 Workshop Manual
 - Setting Reading Goals Perkins Engine Model 2200 Workshop Manual
 - Carving Out Dedicated Reading Time
12. Sourcing Reliable Information of Perkins Engine Model 2200 Workshop Manual
 - Fact-Checking eBook Content of Perkins Engine Model 2200 Workshop Manual
 - Distinguishing Credible Sources
13. Promoting Lifelong Learning
 - Utilizing eBooks for Skill Development
 - Exploring Educational eBooks
14. Embracing eBook Trends
 - Integration of Multimedia Elements

-
- Interactive and Gamified eBooks

Perkins Engine Model 2200 Workshop Manual Introduction

Perkins Engine Model 2200 Workshop Manual Offers over 60,000 free eBooks, including many classics that are in the public domain. Open Library: Provides access to over 1 million free eBooks, including classic literature and contemporary works. Perkins Engine Model 2200 Workshop Manual Offers a vast collection of books, some of which are available for free as PDF downloads, particularly older books in the public domain. Perkins Engine Model 2200 Workshop Manual : This website hosts a vast collection of scientific articles, books, and textbooks. While it operates in a legal gray area due to copyright issues, its a popular resource for finding various publications. Internet Archive for Perkins Engine Model 2200 Workshop Manual : Has an extensive collection of digital content, including books, articles, videos, and more. It has a massive library of free downloadable books. Free-eBooks Perkins Engine Model 2200 Workshop Manual Offers a diverse range of free eBooks across various genres. Perkins Engine Model 2200 Workshop Manual Focuses mainly on educational books, textbooks, and business books. It offers free PDF downloads for educational purposes. Perkins Engine Model 2200 Workshop Manual Provides a large selection of free eBooks in different genres, which are available for download in various formats, including PDF. Finding specific Perkins Engine Model 2200 Workshop Manual, especially related to Perkins Engine Model 2200 Workshop Manual, might be challenging as theyre often artistic creations rather than practical blueprints. However, you can explore the following steps to search for or create your own Online Searches: Look for websites, forums, or blogs dedicated to Perkins Engine Model 2200 Workshop Manual, Sometimes enthusiasts share their designs or concepts in PDF format. Books and Magazines Some Perkins Engine Model 2200 Workshop Manual books or magazines might include. Look for these in online stores or libraries. Remember that while Perkins Engine Model 2200 Workshop Manual, sharing copyrighted material without permission is not legal. Always ensure youre either creating your own or obtaining them from legitimate sources that allow sharing and downloading. Library Check if your local library offers eBook lending services. Many libraries have digital catalogs where you can borrow Perkins Engine Model 2200 Workshop Manual eBooks for free, including popular titles. Online Retailers: Websites like Amazon, Google Books, or Apple Books often sell eBooks. Sometimes, authors or publishers offer promotions or free periods for certain books. Authors Website Occasionally, authors provide excerpts or short stories for free on their websites. While this might not be the Perkins Engine Model 2200 Workshop Manual full book , it can give you a taste of the authors writing style. Subscription Services Platforms like Kindle Unlimited or Scribd offer subscription-based access to a wide range of Perkins Engine Model 2200 Workshop Manual eBooks, including some popular titles.

FAQs About Perkins Engine Model 2200 Workshop Manual Books

What is a Perkins Engine Model 2200 Workshop Manual PDF? A PDF (Portable Document Format) is a file format developed by Adobe that preserves the layout and formatting of a document, regardless of the software, hardware, or operating system used to view or print it. **How do I create a Perkins Engine Model 2200 Workshop Manual PDF?** There are several ways to create a PDF: Use software like Adobe Acrobat, Microsoft Word, or Google Docs, which often have built-in PDF creation tools. Print to PDF: Many applications and operating systems have a "Print to PDF" option that allows you to save a document as a PDF file instead of printing it on paper. Online converters: There are various online tools that can convert different file types to PDF. **How do I edit a Perkins Engine Model 2200 Workshop Manual PDF?** Editing a PDF can be done with software like Adobe Acrobat, which allows direct editing of text, images, and other elements within the PDF. Some free tools, like PDFescape or Smallpdf, also offer basic editing capabilities. **How do I convert a Perkins Engine Model 2200 Workshop Manual PDF to another file format?** There are multiple ways to convert a PDF to another format: Use online converters like Smallpdf, Zamzar, or Adobe Acrobats export feature to convert PDFs to formats like Word, Excel, JPEG, etc. Software like Adobe Acrobat, Microsoft Word, or other PDF editors may have options to export or save PDFs in different formats. **How do I password-protect a Perkins Engine Model 2200 Workshop Manual PDF?** Most PDF editing software allows you to add password protection. In Adobe Acrobat, for instance, you can go to "File" -> "Properties" -> "Security" to set a password to restrict access or editing capabilities. Are there any free alternatives to Adobe Acrobat for working with PDFs? Yes, there are many free alternatives for working with PDFs, such as: LibreOffice: Offers PDF editing features. PDFsam: Allows splitting, merging, and editing PDFs. Foxit Reader: Provides basic PDF viewing and editing capabilities. How do I compress a PDF file? You can use online tools like Smallpdf, ILovePDF, or desktop software like Adobe Acrobat to compress PDF files without significant quality loss. Compression reduces the file size, making it easier to share and download. Can I fill out forms in a PDF file? Yes, most PDF viewers/editors like Adobe Acrobat, Preview (on Mac), or various online tools allow you to fill out forms in PDF files by selecting text fields and entering information. Are there any restrictions when working with PDFs? Some PDFs might have restrictions set by their creator, such as password protection, editing restrictions, or print restrictions. Breaking these restrictions might require specific software or tools, which may or may not be legal depending on the circumstances and local laws.

Find Perkins Engine Model 2200 Workshop Manual :

polar watch manual

poetic devices pre test answer key

[point blank the executioner](#)

[pogil gas variables key](#)

polar mohr guillotine manual 58e

pokemon xd ps3 guide

[polaris 325 magnum service manual](#)

~~[pogil activities for ap biology membrane function worksheet](#)~~

[pogil neuron structure answers](#)

~~[polaris atv cyclone 1985-1995 factory service repair manual](#)~~

pogil cell cycle regulation answer key

pogil ap bio transport in cells keu

pogil activity cell size answer key

[polaris 90 90x scrambler parts manual catalog 2002](#)

poem with hyperbole repition rhyme simile alliteration

Perkins Engine Model 2200 Workshop Manual :

pdf knowledge based decision support system - Jun 22 2023

web chapter 2 decision support systems the chapter is meant to familiarize the reader with the general notions concerning a well defined class of information systems namely the

[knowledge based decision support systems techniques and](#) - May 09 2022

web mar 28 2017 this chapter has presented a decision support system driven by a robust knowledge management framework to aid the respondent sales marketing agent of

[chapter 2 decision support systems springer](#) - May 21 2023

web jun 10 2014 abstract knowledge based decision support systems kbds have evolved greatly over the last few decades the key technologies underpinning the

[decision support systems based on knowledge management](#) - Mar 07 2022

web feb 23 2023 this study offers a merging decision making support framework that combines a knowledge based system with a learning based approach to give and

[knowledge based decision support system springerlink](#) - Jan 17 2023

web aug 1 2020 decision support systems dsss are computer programs that by using expert knowledge simulation models and or databases are of assistance in the

handbook on decision support systems 2 dandelon com - Apr 08 2022

web jul 23 2018 however knowledge and km activities are key components in how the manager uses the system i e the direction of the analysis that he carries out and the

non knowledge based decision support system springerlink - Jan 05 2022

web decision support systems getting the books chapter 2 knowledge based decision support systems now is not type of challenging means you could not by yourself going

decision support system and knowledge based strategic - Jul 11 2022

web jan 1 2000 i overview of knowledge based systems a knowledge based expert systems artificial intelligence ai is a term that includes many subdisciplines

from data and models to decision support systems lessons - Sep 13 2022

web dec 31 2015 decision support systems dss are popular tools that assist decision making in an organisation the importance of knowledge management km is also

chapter 2 knowledge based decision support systems - Aug 24 2023

web 2 2 decision support systems dss and knowledge based decision support systems kb dss decision support is a context free expression it means different

intelligent expert decision support systems methodologies - Dec 04 2021

web cdsss can be classified into two types of systems knowledge based support systems that are defined by a well established set of rules that guide decisions based on the

sustainable knowledge based decision support systems - Dec 16 2022

web jan 1 2015 open access decision support systems dss are popular tools that assist decision making in an organisation the importance of knowledge management km

handbook on decision support systems 1 dandelon com - Aug 12 2022

web may 5 2015 the last chapter evaluating decision support system projects reviews and discusses the tools and issues associated with assessing proposals for dss

introduction to decision support systems springerlink - Nov 15 2022

web aug 10 2021 model based decision support systems dsss employ various types of models such as statistical optimization simulation or rule based models are used to

decision support systems knowledge management tools - Feb 06 2022

web intelligent expert decision support systems methodologies applications and challenges 10 4018 978 1 7998 9023 2 ch024 in this chapter the authors present

decision support system and knowledge based strategic - Oct 14 2022

web part i foundations of decision support systems chapter 1 the decision making process in a complex situation 3 alex bennet and david bennet chapter 2

pdf knowledge based decision support systems a - Apr 20 2023

web knowledge based decision support systems kbdss have evolved greatly over the last few decades the key technologies underpinning the development of kbdss can be

knowledge based decision support system kbdss - Jul 23 2023

web nov 14 2015 pdf on nov 14 2015 kyungyong chung and others published knowledge based decision support system find read and cite all the research you need on

clinical decision support system an overview sciencedirect - Oct 02 2021

decision support systems concepts and resources for managers - Jun 10 2022

web chapter 14 spreadsheet based decision support systems 277 michelle m h seref and ravindra k ahuja chapter 15 multi criteria decision support 299 david l

chapter 2 knowledge based decision support systems - Nov 03 2021

pdf decision support systems researchgate - Feb 18 2023

web aug 14 2017 1 sustainable knowledge based decision support systems dss perspectives new challenges and recent advance 1 1 evolution of decision making and

knowledge based decision support systems a survey - Mar 19 2023

web nov 14 2015 this special issue covers some of the hottest topics in knowledge based decision support systems including decision support for convergence knowledge

panino al prosciutto anna s archive - Nov 05 2022

web watch charles bukowski panino al prosciutto full movie online free like 123movies fmovies putlocker netflix or direct download torrent charles bukowski panino al

charles bukowski panino al prosciutto capitolo 2 - Nov 24 2021

charles bukowski panino registration joniandfriends org - Jan 27 2022

web capitolo 2 del romanzo panino al prosciutto di charles bukowski charlesbukowski paninoalprosciutto leggere

charles bukowski wikipedi - May 11 2023

web sep 21 2023 [lettura del quarantaseiesimo capitolo del romanzo di charles bukowski panino al prosciutto](#)

charles bukowski wikipedia - Aug 02 2022

web charles bukowski a németországban született 1920-ban heinrich karl bukowski néven Édesanyja a német katharina fett édesapjával a német amerikai

charles bukowski panino al prosciutto cap 56 di 58 - Dec 26 2021

web sep 5 2023 [lettura del trentesimo capitolo del romanzo di charles bukowski panino al prosciutto](#)

[charles bukowski panino al prosciutto cap 30 youtube](#) - Oct 24 2021

[charles bukowski panino al prosciutto cap 58 di 58 youtube](#) - Aug 14 2023

web want to read kindle 10 99 rate this book in una los angeles periferica e prostrata dalla grande depressione henry chinaski adolescente ribelle figlio di immigrati tedeschi

panino al prosciutto charles bukowski google books - Oct 04 2022

web henry charles bukowski bu:'kaʊski boo kow skee born heinrich karl bukowski german 'haɪnrɪç 'kaʁl bu'kɔfski august 16 1920 march 9 1994 was an american

charles bukowski panino darelava - Feb 25 2022

web oct 1 2023 [charles bukowski panino al prosciutto cap 56 di 58 bobby long 3 subscribers subscribe 0 no views 2 minutes ago charles bukowski panino al](#)

[charles bukowski yazarına ait tüm kitaplar kitapyardu](#) - Jun 12 2023

charles bukowski 16 agosto 1920 9 mart 1994 asıl adı heinrich karl bukowski olan amerikalı yazar ve şairdir yapıtlarında bazen henry chinaski ismini de kullanmıştır hayatının çoğunu abd nin los angeles şehrinde geçirmiştir eserlerinde genellikle toplum dışı insanlar ile depresyonu konu alması ve alkolizme yatkın bir hayat tarzını anlatmasıyla ünlüdür bunun nedeni olarak kendisinin bu hayatı yaşaması gösterilebilir

charles bukowski panino al prosciutto limetorrents lol - Sep 03 2022

web jun 29 2023 [beatrice bello 105 subscribers subscribe 12 views 1 day ago in questo episodio di un libro con bea continuiamo a parlare di bukowski leggendo assieme](#)

charles bukowski panino al prosciutto cap 46 di 58 - Apr 10 2023

web panino al prosciutto bukowski charles amazon com tr [Çerez tercihlerinizi seçin alışveriş deneyiminizi geliştirmek hizmetlerimizi sunmak müşterilerin hizmetlerimizi](#)

panino al prosciutto by bukowski charles z library - Feb 08 2023

web mar 31 2023 [brief summary of book panino al prosciutto by charles bukowski here is a quick description and cover](#)

image of book panino al prosciutto written by charles

pdf epub panino al prosciutto download - Dec 06 2022

web henry chinaski l abituale alter ego di gran parte dei romanzi di bukowski qui è ancora un ragazzo figlio di immigrati

tedeschi alla scoperta della sua america attraverso le

charles bukowski panino al prosciutto 1 ed - Apr 29 2022

web bukowski charles bukowski panino al prosciutto ham on charles bukowski bukowski risultato charles hank bukowski

share charles hank bukowski diretto 3477 kb s

panino al prosciutto bukowski charles amazon com tr - Mar 09 2023

web panino al prosciutto by bukowski charles z library main panino al prosciutto panino al prosciutto bukowski charles 5 0 5

0 0 comments categories cucina panini

panino col prosciutto paperback 28 january 2010 □□□ □□□□□□ - Mar 29 2022

web charles bukowski panino 1 charles bukowski panino recognizing the showing off ways to get this ebook charles bukowski

panino is additionally useful you have

charles bukowski panino al prosciutto in 30 minuti - Jul 01 2022

web aug 24 2021 1 ed sugarco 1983 dai un occhiata alle mie inserzioni gli oggetti saranno inviati avvolti e protetti

panino al prosciutto by charles bukowski goodreads - Jul 13 2023

web charles bukowski yazarına ait tüm eserleri ve kitapları inceleyebilirsiniz

charles bukowski kitapları ve tüm eserleri d r - Sep 15 2023

web oct 2 2023 lettura del romanzo di charles bukowski panino al prosciutto del 1982 il podcast di tutto il romanzo youtube

com playlist list plg5faswkum acmdj

charles bukowski wikipedia - May 31 2022

web buy panino col prosciutto online on amazon eg at best prices fast and free shipping free returns cash on delivery

available on eligible purchase

charles bukowski poetry foundation - Jan 07 2023

web bukowski charles in una los angeles periferica e prostrata dalla grande depressione henry chinaski adolescente ribelle

figlio di immigrati tedeschi vive il suo apprendistato

ti nspire for dummies 2nd edition wiley - Aug 14 2023

web with updated screenshots and examples ti nspire for dummies provides practical hands on instruction to help students

make the most of this revolutionary graphing

ti nspire for dummies by jeff mcalla open library - Feb 08 2023

web shows how to get maximum value from this versatile math tool with updated screenshots and examples ti nspire for dummies provides practical hands on instruction to help

[ti nspire for dummies guide books acm digital library](#) - Aug 02 2022

web with updated screenshots and examples ti nspire for dummies provides practical hands on instruction to help students make the most of this revolutionary graphing

ti nspire tutorial 1 fundamentals youtube - Feb 25 2022

web mar 26 2016 ti nspire for dummies explore book buy on amazon a ti nspire file that holds problems and pages is a document you can manage your ti nspire documents

ti nspire for dummies 2nd edition paperback - Apr 10 2023

web jan 27 2009 ti nspire for dummies steve ouellette john wiley sons jan 27 2009 computers 360 pages that ti nspire handheld is unlike any math tool you ve ever

ti nspire for dummies 2nd edition amazon com - May 11 2023

web may 20 2011 ti nspire for dummies 2nd edition paperback illustrated 20 may 2011 the ti nspire graphing calculator is popular among high school and college students as

products and accessories for your ti nspire dummies - Dec 26 2021

[ti nspire for dummies jeff mccalla steve ouellette google](#) - Dec 06 2022

web classes as well as students taking the sat psat and act exams this fully updated guide covers all enhancements to the ti nspire including the touchpad and the updated

wiley ti nspire for dummies 2nd edition 978 1 118 00466 1 - Nov 05 2022

web amazon in buy ti nspire for dummies for dummies series book online at best prices in india on amazon in read ti nspire for dummies for dummies series book

shortcuts for managing documents on your ti nspire dummies - Jan 27 2022

web mar 26 2016 ti nspire for dummies explore book buy on amazon a few ti nspire products are worth mentioning here the functionality of ti nspire computer software

[ti nspire for dummies](#) - Jun 12 2023

web jun 7 2011 published june 7 2011 buy on amazon overview the updated guide to the newest graphing calculator from texas instruments the ti nspire graphing calculator is

[ti nspire for dummies steve ouellette google books](#) - Mar 09 2023

web oct 17 2020 learn to use all features of the new touchpad view graphical algebraic numeric geometric and written

formats see and make connections among multiple

ti nspire for dummies for dummies computer tech - Mar 29 2022

web hi this video or tutorial will talk about the basic fundamental actions on the ti nspire i ll be uploading more videos in the future subscribe feel free t

ti nspire for dummies livebrary com overdrive - Jan 07 2023

web may 9 2011 its use is allowed on the major college entrance exams this book is a nuts and bolts guide to working with the ti nspire providing everything you need to get up

ti nspire for dummies cheat sheet - Jul 13 2023

web feb 17 2022 the ti nspire device is the most sophisticated handheld graphing calculator available allowing users to display and evaluate values symbolically and to reuse the

[ti nspire for dummies 2nd ed by jeff mccalla ebook](#) - Jul 01 2022

web may 9 2011 shows how to get maximum value from this versatile math tool with updated screenshots and examples ti nspire for dummies provides practical hands on

[ti nspire for dummies by jeff mccalla overdrive](#) - May 31 2022

web with updated screenshots and examples ti nspire for dummies provides practical hands on instruction to help students make the most of this revolutionary graphing

buy ti nspire for dummies for dummies series book online - Oct 04 2022

web aug 10 2014 paperback the third edition of this book has been updated for the 2016 17 school year at a breakneck pace students teachers and schools around the world

the ti nspire for beginners ti nspire tm tutorials getting - Sep 03 2022

web search acm digital library search search advanced search

[ti nspire for dummies 2nd edition programmer books](#) - Apr 29 2022

web ti nspire versus ti nspire cas the ti nspire product line includes ti nspire and ti nspire cas both in the handheld and as a computer application the ti nspire