

# TUBE ROUTING

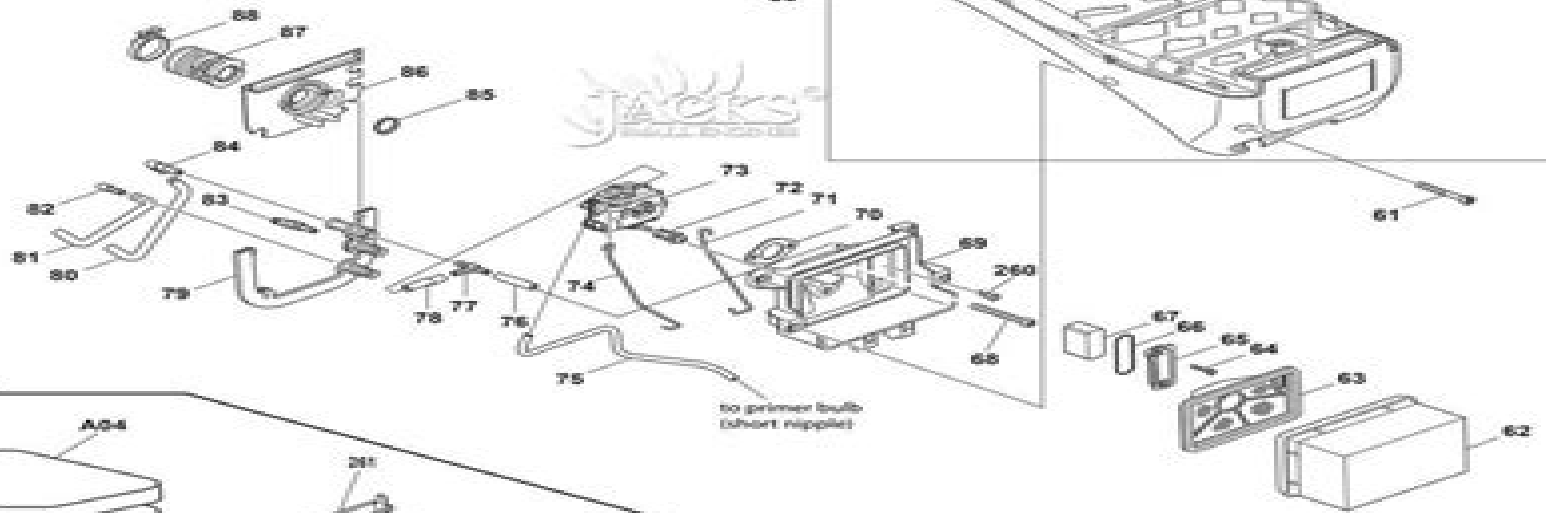

## 5+1 Filter Set

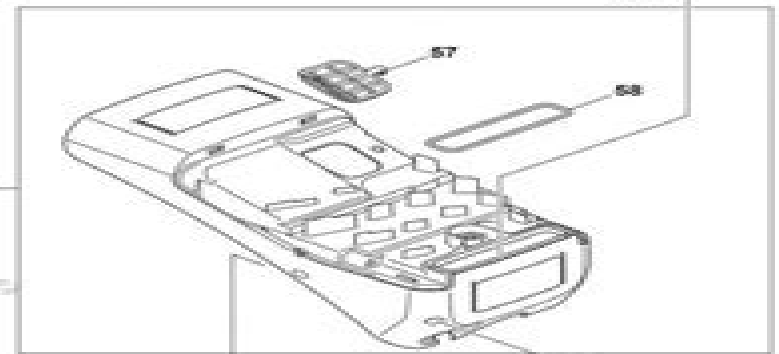
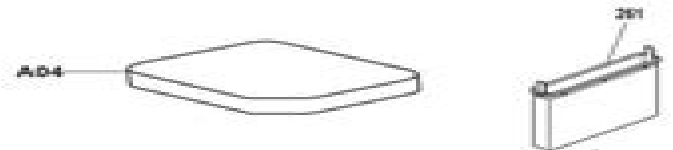
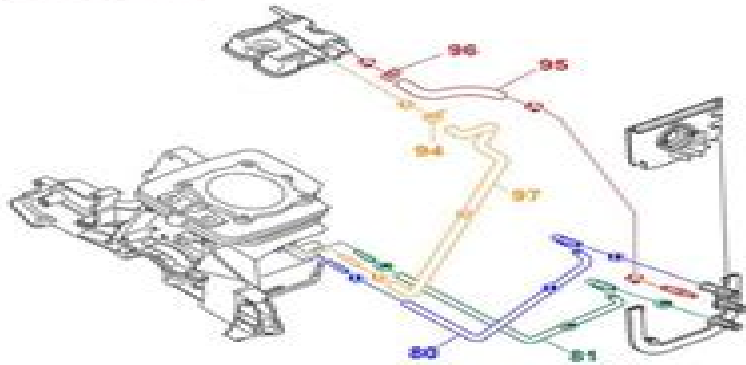
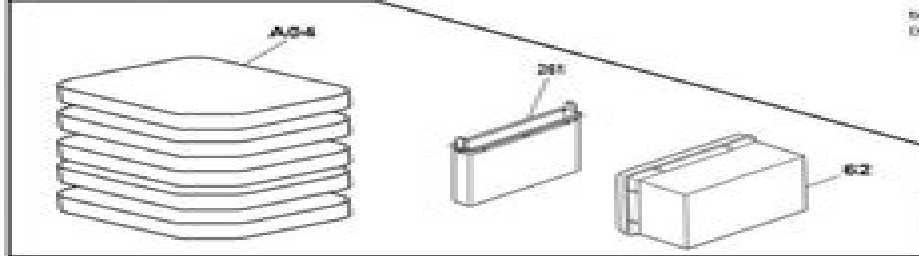

# Scotts 2046h Repair Manual

**David Kirk**



## **Scotts 2046h Repair Manual:**

Thank you enormously much for downloading **Scotts 2046h Repair Manual**. Most likely you have knowledge that, people have look numerous time for their favorite books gone this Scotts 2046h Repair Manual, but stop happening in harmful downloads.

Rather than enjoying a fine PDF when a cup of coffee in the afternoon, then again they juggled in the manner of some harmful virus inside their computer. **Scotts 2046h Repair Manual** is manageable in our digital library an online entrance to it is set as public in view of that you can download it instantly. Our digital library saves in combined countries, allowing you to get the most less latency epoch to download any of our books in the manner of this one. Merely said, the Scotts 2046h Repair Manual is universally compatible subsequent to any devices to read.

<https://crm.avenza.com/results/book-search/fetch.php/repair%20flat%20tire%20bike.pdf>

## **Table of Contents Scotts 2046h Repair Manual**

1. Understanding the eBook Scotts 2046h Repair Manual
  - The Rise of Digital Reading Scotts 2046h Repair Manual
  - Advantages of eBooks Over Traditional Books
2. Identifying Scotts 2046h Repair Manual
  - Exploring Different Genres
  - Considering Fiction vs. Non-Fiction
  - Determining Your Reading Goals
3. Choosing the Right eBook Platform
  - Popular eBook Platforms
  - Features to Look for in an Scotts 2046h Repair Manual
  - User-Friendly Interface
4. Exploring eBook Recommendations from Scotts 2046h Repair Manual
  - Personalized Recommendations
  - Scotts 2046h Repair Manual User Reviews and Ratings

- Scotts 2046h Repair Manual and Bestseller Lists
- 5. Accessing Scotts 2046h Repair Manual Free and Paid eBooks
  - Scotts 2046h Repair Manual Public Domain eBooks
  - Scotts 2046h Repair Manual eBook Subscription Services
  - Scotts 2046h Repair Manual Budget-Friendly Options
- 6. Navigating Scotts 2046h Repair Manual eBook Formats
  - ePub, PDF, MOBI, and More
  - Scotts 2046h Repair Manual Compatibility with Devices
  - Scotts 2046h Repair Manual Enhanced eBook Features
- 7. Enhancing Your Reading Experience
  - Adjustable Fonts and Text Sizes of Scotts 2046h Repair Manual
  - Highlighting and Note-Taking Scotts 2046h Repair Manual
  - Interactive Elements Scotts 2046h Repair Manual
- 8. Staying Engaged with Scotts 2046h Repair Manual
  - Joining Online Reading Communities
  - Participating in Virtual Book Clubs
  - Following Authors and Publishers Scotts 2046h Repair Manual
- 9. Balancing eBooks and Physical Books Scotts 2046h Repair Manual
  - Benefits of a Digital Library
  - Creating a Diverse Reading Collection Scotts 2046h Repair Manual
- 10. Overcoming Reading Challenges
  - Dealing with Digital Eye Strain
  - Minimizing Distractions
  - Managing Screen Time
- 11. Cultivating a Reading Routine Scotts 2046h Repair Manual
  - Setting Reading Goals Scotts 2046h Repair Manual
  - Carving Out Dedicated Reading Time
- 12. Sourcing Reliable Information of Scotts 2046h Repair Manual
  - Fact-Checking eBook Content of Scotts 2046h Repair Manual
  - Distinguishing Credible Sources

13. Promoting Lifelong Learning
  - Utilizing eBooks for Skill Development
  - Exploring Educational eBooks
14. Embracing eBook Trends
  - Integration of Multimedia Elements
  - Interactive and Gamified eBooks

### **Scotts 2046h Repair Manual Introduction**

In today's digital age, the availability of Scotts 2046h Repair Manual books and manuals for download has revolutionized the way we access information. Gone are the days of physically flipping through pages and carrying heavy textbooks or manuals. With just a few clicks, we can now access a wealth of knowledge from the comfort of our own homes or on the go. This article will explore the advantages of Scotts 2046h Repair Manual books and manuals for download, along with some popular platforms that offer these resources. One of the significant advantages of Scotts 2046h Repair Manual books and manuals for download is the cost-saving aspect. Traditional books and manuals can be costly, especially if you need to purchase several of them for educational or professional purposes. By accessing Scotts 2046h Repair Manual versions, you eliminate the need to spend money on physical copies. This not only saves you money but also reduces the environmental impact associated with book production and transportation. Furthermore, Scotts 2046h Repair Manual books and manuals for download are incredibly convenient. With just a computer or smartphone and an internet connection, you can access a vast library of resources on any subject imaginable. Whether you're a student looking for textbooks, a professional seeking industry-specific manuals, or someone interested in self-improvement, these digital resources provide an efficient and accessible means of acquiring knowledge. Moreover, PDF books and manuals offer a range of benefits compared to other digital formats. PDF files are designed to retain their formatting regardless of the device used to open them. This ensures that the content appears exactly as intended by the author, with no loss of formatting or missing graphics. Additionally, PDF files can be easily annotated, bookmarked, and searched for specific terms, making them highly practical for studying or referencing. When it comes to accessing Scotts 2046h Repair Manual books and manuals, several platforms offer an extensive collection of resources. One such platform is Project Gutenberg, a nonprofit organization that provides over 60,000 free eBooks. These books are primarily in the public domain, meaning they can be freely distributed and downloaded. Project Gutenberg offers a wide range of classic literature, making it an excellent resource for literature enthusiasts. Another popular platform for Scotts 2046h Repair Manual books and manuals is Open Library. Open Library is an initiative of the Internet Archive, a nonprofit organization dedicated to digitizing cultural artifacts and making them accessible to the public. Open Library hosts

millions of books, including both public domain works and contemporary titles. It also allows users to borrow digital copies of certain books for a limited period, similar to a library lending system. Additionally, many universities and educational institutions have their own digital libraries that provide free access to PDF books and manuals. These libraries often offer academic texts, research papers, and technical manuals, making them invaluable resources for students and researchers. Some notable examples include MIT OpenCourseWare, which offers free access to course materials from the Massachusetts Institute of Technology, and the Digital Public Library of America, which provides a vast collection of digitized books and historical documents. In conclusion, Scotts 2046h Repair Manual books and manuals for download have transformed the way we access information. They provide a cost-effective and convenient means of acquiring knowledge, offering the ability to access a vast library of resources at our fingertips. With platforms like Project Gutenberg, Open Library, and various digital libraries offered by educational institutions, we have access to an ever-expanding collection of books and manuals. Whether for educational, professional, or personal purposes, these digital resources serve as valuable tools for continuous learning and self-improvement. So why not take advantage of the vast world of Scotts 2046h Repair Manual books and manuals for download and embark on your journey of knowledge?

### **FAQs About Scotts 2046h Repair Manual Books**

How do I know which eBook platform is the best for me? Finding the best eBook platform depends on your reading preferences and device compatibility. Research different platforms, read user reviews, and explore their features before making a choice. Are free eBooks of good quality? Yes, many reputable platforms offer high-quality free eBooks, including classics and public domain works. However, make sure to verify the source to ensure the eBook credibility. Can I read eBooks without an eReader? Absolutely! Most eBook platforms offer webbased readers or mobile apps that allow you to read eBooks on your computer, tablet, or smartphone. How do I avoid digital eye strain while reading eBooks? To prevent digital eye strain, take regular breaks, adjust the font size and background color, and ensure proper lighting while reading eBooks. What the advantage of interactive eBooks? Interactive eBooks incorporate multimedia elements, quizzes, and activities, enhancing the reader engagement and providing a more immersive learning experience. Scotts 2046h Repair Manual is one of the best book in our library for free trial. We provide copy of Scotts 2046h Repair Manual in digital format, so the resources that you find are reliable. There are also many Ebooks of related with Scotts 2046h Repair Manual. Where to download Scotts 2046h Repair Manual online for free? Are you looking for Scotts 2046h Repair Manual PDF? This is definitely going to save you time and cash in something you should think about. If you trying to find then search around for online. Without a doubt there are numerous these available and many of them have the freedom. However without doubt you

receive whatever you purchase. An alternate way to get ideas is always to check another Scotts 2046h Repair Manual. This method for see exactly what may be included and adopt these ideas to your book. This site will almost certainly help you save time and effort, money and stress. If you are looking for free books then you really should consider finding to assist you try this. Several of Scotts 2046h Repair Manual are for sale to free while some are payable. If you arent sure if the books you would like to download works with for usage along with your computer, it is possible to download free trials. The free guides make it easy for someone to free access online library for download books to your device. You can get free download on free trial for lots of books categories. Our library is the biggest of these that have literally hundreds of thousands of different products categories represented. You will also see that there are specific sites catered to different product types or categories, brands or niches related with Scotts 2046h Repair Manual. So depending on what exactly you are searching, you will be able to choose e books to suit your own need. Need to access completely for Campbell Biology Seventh Edition book? Access Ebook without any digging. And by having access to our ebook online or by storing it on your computer, you have convenient answers with Scotts 2046h Repair Manual To get started finding Scotts 2046h Repair Manual, you are right to find our website which has a comprehensive collection of books online. Our library is the biggest of these that have literally hundreds of thousands of different products represented. You will also see that there are specific sites catered to different categories or niches related with Scotts 2046h Repair Manual So depending on what exactly you are searching, you will be able tochoose ebook to suit your own need. Thank you for reading Scotts 2046h Repair Manual. Maybe you have knowledge that, people have search numerous times for their favorite readings like this Scotts 2046h Repair Manual, but end up in harmful downloads. Rather than reading a good book with a cup of coffee in the afternoon, instead they juggled with some harmful bugs inside their laptop. Scotts 2046h Repair Manual is available in our book collection an online access to it is set as public so you can download it instantly. Our digital library spans in multiple locations, allowing you to get the most less latency time to download any of our books like this one. Merely said, Scotts 2046h Repair Manual is universally compatible with any devices to read.

### **Find Scotts 2046h Repair Manual :**

**repair flat tire bike**

[renault twingo 2002 service manual](#)

[repair manual for 8480 case baler](#)

*repair manual akai disc*

[repair manual for 98 town car](#)

[render bookragscdn-com s3-amazonaws-com-25](#)



[repair manual for 2015 toyota rav4](#)

**repair manual 1994 chrysler concorde**

[repair broken cassette tape](#)

[repair manual for a 2007 chevy trailblazer](#)

[renounced southwestern shifters series book 10](#)

[repair manual dell inspiron 1000](#)

[repair manual for 2008 pontiac g5](#)

[repair manual for 2015 avenger](#)

[repair manual 99 chrysler cirrus v6](#)

### **Scotts 2046h Repair Manual :**

*futa photos and premium high res pictures getty images* - Jan 27 2022

web browse getty images premium collection of high quality authentic futa stock photos royalty free images and pictures futa stock photos are available in a variety of sizes

[guide bretagne 2018 petit futa c copy](#) - Apr 29 2022

web guide bretagne 2018 petit futa c a wonderful fictional value filled with natural feelings lies an immersive symphony waiting to be embraced constructed by an outstanding

**bretagne 2017 petit futa c guides region glyn l francis pdf** - Nov 05 2022

web feb 21 2023 if you ally need such a referred bretagne 2017 petit futa c guides region ebook that will pay for you worth acquire the no question best seller from us currently

**pdf bretagne 2017 petit futa c guides region** - Aug 14 2023

web bretagne 2017 petit futa c guides region petit futé reims by dominique auzias feb 19 2023 web the petit ballon restaurant is ace archaeological approaches to cultural identity

*petit futa c bretagne wrbb neu edu* - Jul 01 2022

web 4 petit futa c bretagne 2020 01 16 translation strategies dealing with character names and complex translation strategies used in dealing with the dual audience in hans

*petit futa c bretagne uniport edu ng* - May 31 2022

web petit futa c bretagne 1 7 downloaded from uniport edu ng on march 14 2023 by guest petit futa c bretagne as recognized adventure as with ease as experience more or

*futa videos xvideos com* - Nov 24 2021

web futa fuck futanari yoga class reincarnation of the feminine trailer 67 sec 67 sec futanari ca 1080p futa x girl 3d porn  
2023 full movie hd 42 min 42 min

*guide bretagne 2018 petit futa c pdf download only china int* - Sep 22 2021

web guide bretagne 2018 petit futa c pdf introduction guide bretagne 2018 petit futa c pdf download only don t go to school  
maire zepf 2017 benno is really excited for

*bretagne 2019 petit futa c guides region* - Feb 08 2023

web it will utterly ease you to see guide bretagne 2019 petit futa c guides region as you such as by searching the title  
publisher or authors of guide you truly want you can discover

**petit futé bretagne by petit futé media joomlashine com** - Mar 29 2022

web petit futé bretagne by petit futé petit futé bretagne by petit futé le petit fut series librarything socit blogguine marie hlne  
martin get textbooks new textbooks used

*futanari 5 665 vidéos iwank tv* - Dec 26 2021

web il ya 9 mois 01 30 xhamster futanari transexuelle il ya 3 ans 17 01 hdsex futanari branlette avec les pieds hier 24 27

keekass orgasme compilation compil creampie

*guide bretagne 2018 petit futa c pdf pdf voto unéal edu* - Jan 07 2023

web inspiring within the pages of guide bretagne 2018 petit futa c pdf a mesmerizing literary creation penned by a  
celebrated wordsmith readers attempt an enlightening odyssey

**bretagne 2019 carnet petit futa c carnet de voyag pdf** - Jul 13 2023

web 2019 carnet petit futa c carnet de voyag a literary masterpiece penned by way of a renowned author readers set about a  
transformative journey unlocking the secrets and

*free bretagne 2019 petit futa c guides region* - Jun 12 2023

web ensuite aide les petits lutins à rejoindre leur champignon en repassant sur les pointillés avec ton feutre ce livre contient  
toutes sortes d exercices ludiques qui aident votre

*guide bretagne 2018 petit futa c full pdf wrbb neu* - Mar 09 2023

web right here we have countless book guide bretagne 2018 petit futa c and collections to check out we additionally allow  
variant types and next type of the books to browse the

**free futa porn videos 2 339 tubesafari com** - Oct 24 2021

web real life futanari hot blonde futa chick fuck her sexy psychotherapist 10 months ago 2 02 bowsette x toadette by hard  
degenerate 8 months ago 8 19 queen royally

*bretagne 2017 petit futa c guides region pdf* - Oct 04 2022

web aug 7 2023 bretagne 2017 petit futa c guides region bretagne 2017 petit futa c guides region 2 downloaded from avantevapehouse com on 2020 02 29 by guest

[bretagne 2019 petit futa c guides region pdf monograf](#) - Sep 03 2022

web comprehending as well as arrangement even more than supplementary will come up with the money for each success neighboring to the statement as well as insight of this

**petit futa c guide du mariage en bretagne pdf voto unéal edu br** - Aug 02 2022

web decoding petit futa c guide du mariage en bretagne pdf revealing the captivating potential of verbal expression in a period characterized by interconnectedness and an

**bretagne 2017 petit futa c guides region full pdf clr imymac** - May 11 2023

web bretagne 2017 petit futa c guides region 3 3 1909 for a little girl in dublin it s plasmavores knocking at the door for davros it s a summons from the doctor who

[bretagne 2016 petit futa c guide ra c gion pdf pdf](#) - Dec 06 2022

web bretagne 2016 petit futa c guide ra c gion pdf upload arnold q hayda 2 3 downloaded from elections freep com on july 31 2023 by arnold q hayda southern italy and the

[petit futé bretagne by petit futé darelouva](#) - Feb 25 2022

web may 14 2023 that the original home of the fulani people is futa jallon also known in the french as fouta djallon in the upper guinea highlands of the west african republic of

[bretagne 2019 petit futa c guides region pdf uniport edu](#) - Apr 10 2023

web aug 5 2023 bretagne 2019 petit futa c guides region 2 7 downloaded from uniport edu ng on august 5 2023 by guest concepts are put to critical use including

**delfine lichtvolle botschaften für uns menschen** - Nov 28 2022

web mit lichtvollen botschaften und der liebevollen energie der delfine berührt dieses kartenset uns im herzen sodass wir uns für höhere welten öffnen können die delfine bringen uns in die schwingung der lei

[delfine lichtvolle botschaften für uns menschen amazon de](#) - Mar 01 2023

web delfine lichtvolle botschaften für uns menschen 56 karten mit begleitbuch von jeanne ruland 2013 broschiert isbn kostenloser versand für alle bücher mit versand und verkauf duch amazon

[delfine lichtvolle botschaften für uns menschen shop](#) - Mar 21 2022

web jun 6 2013 mit lichtvollen botschaften und der liebevollen energie der delfine berührt dieses kartenset uns im herzen sodass wir uns für höhere welten öffnen können die delfine bringen uns in die schwingung der leichtigkeit und freude in schöpferische ebene des seins und in neue dimensionen

[delfine lichtvolle botschaften für uns menschen 56 karten mit](#) - Jul 25 2022

web delfine lichtvolle botschaften für uns menschen 56 karten mit begleitbuch jeanne ruland anne mareike schultz 0 00 0

[delfine lichtvolle botschaften für uns menschen google books](#) - Aug 06 2023

web delfine lichtvolle botschaften für uns menschen 56 karten mit begleitbuch authors jeanne ruland anne mareike schultz publisher schirner verlag 2013 isbn 3843490392 9783843490399 length 56 pages export citation bibtex endnote refman

**delfine lichtvolle botschaften für uns menschen jeanne** - Sep 07 2023

web mit lichtvollen botschaften und der liebevollen energie der delfine berührt dieses kartenset uns im herzen sodass wir uns für höhere welten öffnen können die delfine bringen uns in die schwingung der leichtigkeit und freude in schöpferische ebene des seins und in neue dimensionen

**delfine lichtvolle botschaften für uns menschen ruland** - Aug 26 2022

web mit lichtvollen botschaften und der liebevollen energie der delfine berührt dieses kartenset uns im herzen sodass wir uns für höhere welten öffnen können

[delfine lichtvolle botschaften für uns menschen 56 karten mit](#) - Jul 05 2023

web jun 6 2013 amazon com delfine lichtvolle botschaften für uns menschen 56 karten mit begleitbuch 9783843490399 ruland jeanne schultz anne mareike books

**delfine lichtvolle botschaften für uns menschen 56 karten mit** - Oct 08 2023

web mit lichtvollen botschaften und der liebevollen energie der delfine berührt dieses kartenset uns im herzen sodass wir uns für höhere welten öffnen können die delfine bringen uns in die schwingung der leichtigkeit und freude in schöpferische ebene des seins und in neue dimensionen

**amazon com customer reviews delfine lichtvolle botschaften für uns** - Oct 28 2022

web find helpful customer reviews and review ratings for delfine lichtvolle botschaften für uns menschen 56 karten mit begleitbuch at amazon com read honest and unbiased product reviews from our users

[delfine lichtvolle botschaften für uns menschen picclick de](#) - Feb 17 2022

web delfine lichtvolle botschaften für uns menschen 56 k buch zustand gut eur 18 14 zu verkaufen geprüfte second hand artikel certified second hand articles Über 4 134689649987

[delfine lichtvolle botschaften für uns menschen eur 19 95](#) - Apr 21 2022

web delfine lichtvolle botschaften für uns menschen eur 19 95 zu verkaufen versandkosten lieferzeit zahlarten rechnungsversand storno erstattungen rücksendung umtausch anpassung 352471832193

*delfine lichtvolle botschaften für uns menschen ruland* - Jun 04 2023

web mit lichtvollen botschaften und der liebevollen energie der delfine berührt dieses kartenset uns im herzen sodass wir

uns für höhere welten öffnen können die delfine bringen uns in die schwingung der leichtigkeit und freude in schöpferische ebene des seins und in neue dimensionen so können wir in jeder situation im alltag den weg der liebe und

**delfine lichtvolle botschaften für uns menschen ex libris** - Sep 26 2022

web delfine lichtvolle botschaften für uns menschen von jeanne ruland anne mareike schultz aus esoterik portofreie lieferung jetzt bei ex libris zum tiefpreis kaufen

**delfine lichtvolle botschaften für uns menschen amazon de** - Apr 02 2023

web delfine lichtvolle botschaften für uns menschen 56 karten mit begleitbuch 6 juni 2013 isbn kostenloser versand für alle bücher mit versand und verkauf durch amazon

**delfine lichtvolle botschaften für uns menschen 56 karten mit** - May 23 2022

web delfine lichtvolle botschaften für uns menschen 56 karten mit begleitbuch buch finden sie alle bücher von bei der büchersuchmaschine eurobuch com können sie antiquarische und neubücher vergleichen und sofort zum bestpreis bestellen zum verkauf steht folgendes buch sehr gut festpreisangebot

**amazon de kundenrezensionen delfine lichtvolle botschaften für uns** - Dec 30 2022

web finde hilfreiche kundenrezensionen und rezensionsbewertungen für delfine lichtvolle botschaften für uns menschen 56 karten mit begleitbuch auf amazon de lese ehrliche und unvoreingenommene rezensionen von unseren nutzern

**delfine lichtvolle botschaften für uns menschen ruland** - Jan 31 2023

web delfine lichtvolle botschaften für uns menschen 56 karten mit begleitbuch ruland jeanne schultz anne mareike isbn 9783843490399

**delfine lichtvolle botschaften für uns menschen jeanne ruland** - Jun 23 2022

web delfine lichtvolle botschaften für uns menschen paperback isbn 9783843490399 genre mysterie spanning type boekomslag andere formaten

**delfine lichtvolle botschaften für uns menschen m orakelkarten** - May 03 2023

web mit lichtvollen botschaften und der liebevollen energie der delfine berührt dieses kartenset uns im herzen sodass wir uns für höhere welten öffnen können die delfine bringen uns in die schwingung der leichtigkeit und freude in schöpferische ebene des seins und in neue dimensionen

*la caccia film 2023 mymovies it* - Feb 09 2023

web la caccia un film di marco bocci marco bocci controlla bene la messa in scena con un cast che dà le giuste sfumature e una colonna sonora di grande efficacia con laura chiatti filippo nigro paolo pierobon pietero sermonti peppino mazzotta drammatico italia 2023 durata 100 min

la caccia la recensione il mortifero amore fraterno secondo - Oct 05 2022

web may 11 2023 c era una volta la zavorra di un ricordo infiltratosi sotto pelle la sofferenza che si quadruplica diventando un trauma fraterno da spezzare e condividere in famiglia come un segreto

**la caccia film 2022 wikipedia** - Mar 10 2023

web la caccia è un film del 2022 diretto da marco bocci indice 1 trama 2 distribuzione 3 note 4 collegamenti esterni trama dopo la morte del loro padre quattro fratelli si riuniscono dopo molti anni distribuzione

*la caccia trailer ufficiale youtube* - May 12 2023

web apr 19 2023 24 share 4 4k views 3 months ago diretto da marco bocci la caccia arriverà nei cinema l 11 maggio 2023

**la caccia 2022 imdb** - Aug 15 2023

web may 11 2023 la caccia directed by marco bocci with laura chiatti salvatore langella filippo nigro paolo pierobon

la caccia è al cinema la fiaba nera di marco bocci video sky - Jun 01 2022

web may 12 2023 leggi su sky tg24 l articolo la caccia è al cinema la fiaba nera di marco bocci video laura chiatti pietero sermonti filippo nigro e paolo pierobon sono alcuni dei protagonisti del nuovo film

**la caccia film 2023 comingsoon it** - Apr 11 2023

web may 11 2023 la caccia è un film di genere drammatico thriller del 2023 diretto da marco bocci con laura chiatti e filippo nigro uscita al cinema il 11 maggio 2023 durata 100 minuti distribuito da

*caccia all uomo in turchia l incursione della polizia in un* - Feb 26 2022

web sep 6 2023 caccia all uomo in turchia l incursione della polizia in un quartiere di istanbul corriere della sera segui lapresse la polizia turca a caccia del killer che ha provocato la strage nel club reina di istanbul a capodanno uccidendo 39 persone e ferendone altre 70 con ben 180 colpi esplosi

la caccia film 2022 trama cast foto news movieplayer it - Jan 08 2023

web may 11 2023 la caccia è un film di genere drammatico del 2022 diretto da marco bocci con laura chiatti e filippo nigro durata 100 min distribuito in italia da minerva pictures group

la caccia 2023 trailer ufficiale youtube - Jun 13 2023

web jul 26 2023 la caccia 2023 trailer ufficiale s h magazine 615 subscribers subscribe 2 share 365 views 3 months ago marco bocci torna dietro la macchina da presa con il thriller la caccia

**la caccia film trama cast recensione bocci laura chiatti io** - Sep 04 2022

web may 12 2023 la caccia la trama del film

*la caccia serie televisiva wikipedia* - Dec 07 2022

web la caccia la caza è una serie televisiva spagnola composta da 24 episodi creata da agustín martínez e luis moya e diretta da Álvaro ron insieme a salvador garcía ruiz la serie è basata sul romanzo monteperdido di agustín martínez la prima

stagione è stata intitolata la caccia monteperdido la caza

**la caccia trailer youtube** - Aug 03 2022

web titolo la caccia anno 2020 regia marcos pradogenere thriller crimecast renato goes amanda grimaldi juliana schalch tropa de elite naz brasilechi dei

**la caccia trailer ufficiale youtube** - Mar 30 2022

web apr 21 2023 la caccia trailer ufficiale un racconto ad alta tensione e dagli imprevedibili colpi di scena regia di marco bocci un film con laura chiatti filippo nigro paolo pierobon pietero serm

*la caccia film usciti nel 2023 film docu filmitalia* - Jul 02 2022

web premi e festival torino film festival 2022 fuori concorso favolacce un dramma familiare che segue la storia di quattro fratelli tre maschi e una femmina che si riuniscono dopo svariati anni di lontananza per l'improvvisa morte del padre

la caccia miniserie tv in 2 parti 2005 movieplayer it - Dec 27 2021

web jan 16 2005 la caccia miniserie tv in 2 parti 2005 scheda completa del film di massimo spano con andrea osvart claudio amendola alessio boni trama cast trailer gallerie boxoffice premi

la caccia streaming ita 2023 in altadefinizione su cineblog01 - Jan 28 2022

web guarda la caccia streaming community in italiano completamente gratis il video é disponibile anche in scarica download in qualità alta definizione hd 720p full hd 1080p ultra hd 4k la caccia 2023 streaming cineblog01 cb01 senza limiti per tutti

**la caccia yayını İnternette nereden film izlenir justwatch** - Nov 06 2022

web la caccia nerede yayınlanıyor aradığınız online içerikleri netflix ve amazon dahil 7 platformun hangisinden izleyebileceğinizi öğrenin la caccia yayını İnternette nereden film izlenir

**cast completo del film la caccia mymovies** - Apr 30 2022

web un film di marco bocci con laura chiatti filippo nigro paolo pierobon pietero sermonti continua drammatico durata 100 min italia 2023 medusa uscita giovedì 11 maggio 2023 mymonetro la caccia valutazione media 3 15 su 1 recensioni di critica pubblico e dizionari scheda critica pubblico forum cast news trailer foto frasi

**la caccia dall 11 maggio al cinema trailer ufficiale** - Jul 14 2023

web la caccia dall 11 maggio al cinema trailer ufficialeregia marco boccisceneggiatura marco bocci alessandro nicolò alessandro pondistar laura chiatti