

Item	Description	Page
1	Water Pump Indicator	11
2	Trimming Tilt Switch	11
3	Tilt Support Lever	11
4	Adjustment Knobs	11
5	Tilt Tab	26, 27
6	Propeller (not supplied)	26, 27
7	Adjustment Screw of S. Plug	26

Item	Description	Page
8	Water Intake	11
9	Adjustment Level Plug	11
10	Power Trim Tilt Pedestal	11
11	Tilt Switch Switch	11
12	Power Switch	11
13	Remote Control	11
14	Cle and Lanyard Assembly	11

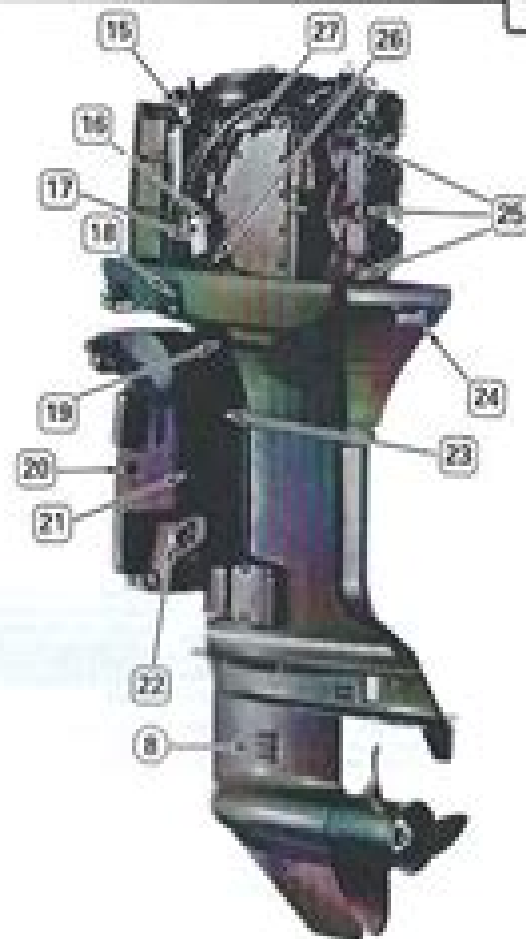

Item	Description	Page
15	Water Muffler Filter	11
16	Water Pump Filter	11
17	Water Pump Filter	11
18	Water Pump Filter	11
19	Water Pump Filter	11
20	Water Pump Filter	11
21	Water Pump Filter	11
22	Water Pump Filter	11
23	Water Pump Filter	11
24	Water Pump Filter	11
25	Water Pump Filter	11

Item	Description	Page
26	Oil Drain Plug	11
27	Model and Serial Number Plate	1
28	Engine Cover Latch	22
29	Spark Plug	22
30	Water Pressure Tap	22
31	Fuel	22

Repair Manual For Omc 70hp Johnson Motor

Yi-Tong Ma



Repair Manual For Omc 70hp Johnson Motor:

Johnson Service-repair Handbook, 40 to 140 Hp, 1965-1983 Kalton C. Lahue,1983 *Outboard Motor Service Manual* Intertec Publishing,1987 Detailed tips on periodic servicing troubleshooting general maintenance and repair are explicitly outlined in this manual Repair is easy with the specifications and step by step repair procedures included for hundreds of models Volume II covers models with 30hp and above

Outboard Motor Service Manual: Motors below 30 hp, 1979

Bibliography of Nautical Books Alan Obin,2000-02 This is the 15th annual edition of the Bibliography of Nautical Books a reference guide to over 14 000 nautical publications It deals specifically with the year 2000

Field & Stream, 1981-08 FIELD STREAM America s largest outdoor sports magazine celebrates the outdoor experience with great stories compelling photography and sound advice while honoring the traditions hunters and fishermen have passed down for generations

The Rudder, 1964 MotorBoating, 1977-09

Rudder Thomas Fleming Day,1964 **Atlantic Fisherman**, 1983 *Service Manual 2 Thru 8* Outboard Marine Corporation, *Field and Stream*, 1981

Farmers and Consumers Market Bulletin, 2011 Diver, Service Manual 60 Thru 70, 1992 Covers models 60 65 and 70 P N 508284 Box P N 508279 *Service Manual 40 Thru 55*, 1992

Johnson Outboard Motors Complete Owner's Manual Pasquale De Marco,2025-04-24 Dive into the world of Johnson outboard motors with this comprehensive and authoritative manual your ultimate guide to maintaining troubleshooting and enhancing the performance of your trusty marine companion Whether you re a seasoned boater or just starting out this manual is your essential resource for keeping your Johnson motor running smoothly and efficiently With clear step by step instructions and detailed illustrations this manual covers everything from routine maintenance to advanced troubleshooting and repair procedures You ll find expert advice on topics such as fuel system maintenance electrical system diagnostics cooling system care and lower unit repair In addition to providing comprehensive maintenance and repair guidance this manual also includes valuable information on performance enhancement techniques Learn how to fine tune your carburetor adjust your ignition timing and select the right propeller for optimal performance You ll also find tips on winterizing your motor and storing it properly to ensure its longevity Written by a team of experienced marine mechanics and enthusiasts this manual is the ultimate resource for Johnson outboard motor owners Whether you re looking to perform routine maintenance troubleshoot a problem or simply learn more about your motor this manual has everything you need to keep your Johnson running at its best Inside this comprehensive guide you ll discover In depth coverage of routine maintenance procedures including oil changes spark plug replacement and fuel system cleaning Expert troubleshooting advice for diagnosing and resolving common engine problems Step by step instructions for performing advanced repairs such as valve adjustments and cylinder head removal Valuable tips on enhancing your motor s performance including fine tuning the carburetor and adjusting the ignition timing Comprehensive guidance on winterizing and storing your motor properly to protect it from the elements With its clear instructions detailed illustrations and expert

advice this manual is your essential companion for maintaining troubleshooting and enhancing the performance of your Johnson outboard motor Get your copy today and unlock the full potential of your marine powerhouse If you like this book write a review on google books

Service Manual 120 Thru 140, 185 Thru 225, 250, 300 Outboard Marine Corporation,1992

Service Manual, Johnson Evinrude Outboard Marine Corporation,1989

Service Manual Outboard Marine Corporation,1992

Service Manual 150, 150c, 175 Outboard Marine Corporation,1992

Eventually, you will agreed discover a other experience and carrying out by spending more cash. nevertheless when? accomplish you acknowledge that you require to acquire those every needs subsequent to having significantly cash? Why dont you attempt to acquire something basic in the beginning? Thats something that will lead you to understand even more a propos the globe, experience, some places, taking into consideration history, amusement, and a lot more?

It is your categorically own times to action reviewing habit. in the course of guides you could enjoy now is **Repair Manual For Omc 70hp Johnson Motor** below.

https://crm.avenza.com/data/book-search/Download_PDFS/Sample_Sponsorship_Letter_For_An_Athlete.pdf

Table of Contents Repair Manual For Omc 70hp Johnson Motor

1. Understanding the eBook Repair Manual For Omc 70hp Johnson Motor
 - The Rise of Digital Reading Repair Manual For Omc 70hp Johnson Motor
 - Advantages of eBooks Over Traditional Books
2. Identifying Repair Manual For Omc 70hp Johnson Motor
 - Exploring Different Genres
 - Considering Fiction vs. Non-Fiction
 - Determining Your Reading Goals
3. Choosing the Right eBook Platform
 - Popular eBook Platforms
 - Features to Look for in an Repair Manual For Omc 70hp Johnson Motor
 - User-Friendly Interface
4. Exploring eBook Recommendations from Repair Manual For Omc 70hp Johnson Motor
 - Personalized Recommendations
 - Repair Manual For Omc 70hp Johnson Motor User Reviews and Ratings
 - Repair Manual For Omc 70hp Johnson Motor and Bestseller Lists
5. Accessing Repair Manual For Omc 70hp Johnson Motor Free and Paid eBooks

- Repair Manual For Omc 70hp Johnson Motor Public Domain eBooks
 - Repair Manual For Omc 70hp Johnson Motor eBook Subscription Services
 - Repair Manual For Omc 70hp Johnson Motor Budget-Friendly Options
6. Navigating Repair Manual For Omc 70hp Johnson Motor eBook Formats
 - ePub, PDF, MOBI, and More
 - Repair Manual For Omc 70hp Johnson Motor Compatibility with Devices
 - Repair Manual For Omc 70hp Johnson Motor Enhanced eBook Features
 7. Enhancing Your Reading Experience
 - Adjustable Fonts and Text Sizes of Repair Manual For Omc 70hp Johnson Motor
 - Highlighting and Note-Taking Repair Manual For Omc 70hp Johnson Motor
 - Interactive Elements Repair Manual For Omc 70hp Johnson Motor
 8. Staying Engaged with Repair Manual For Omc 70hp Johnson Motor
 - Joining Online Reading Communities
 - Participating in Virtual Book Clubs
 - Following Authors and Publishers Repair Manual For Omc 70hp Johnson Motor
 9. Balancing eBooks and Physical Books Repair Manual For Omc 70hp Johnson Motor
 - Benefits of a Digital Library
 - Creating a Diverse Reading Collection Repair Manual For Omc 70hp Johnson Motor
 10. Overcoming Reading Challenges
 - Dealing with Digital Eye Strain
 - Minimizing Distractions
 - Managing Screen Time
 11. Cultivating a Reading Routine Repair Manual For Omc 70hp Johnson Motor
 - Setting Reading Goals Repair Manual For Omc 70hp Johnson Motor
 - Carving Out Dedicated Reading Time
 12. Sourcing Reliable Information of Repair Manual For Omc 70hp Johnson Motor
 - Fact-Checking eBook Content of Repair Manual For Omc 70hp Johnson Motor
 - Distinguishing Credible Sources
 13. Promoting Lifelong Learning
 - Utilizing eBooks for Skill Development

- Exploring Educational eBooks
- 14. Embracing eBook Trends
 - Integration of Multimedia Elements
 - Interactive and Gamified eBooks

Repair Manual For Omc 70hp Johnson Motor Introduction

Free PDF Books and Manuals for Download: Unlocking Knowledge at Your Fingertips In today's fast-paced digital age, obtaining valuable knowledge has become easier than ever. Thanks to the internet, a vast array of books and manuals are now available for free download in PDF format. Whether you are a student, professional, or simply an avid reader, this treasure trove of downloadable resources offers a wealth of information, conveniently accessible anytime, anywhere. The advent of online libraries and platforms dedicated to sharing knowledge has revolutionized the way we consume information. No longer confined to physical libraries or bookstores, readers can now access an extensive collection of digital books and manuals with just a few clicks. These resources, available in PDF, Microsoft Word, and PowerPoint formats, cater to a wide range of interests, including literature, technology, science, history, and much more. One notable platform where you can explore and download free Repair Manual For Omc 70hp Johnson Motor PDF books and manuals is the internet's largest free library. Hosted online, this catalog compiles a vast assortment of documents, making it a veritable goldmine of knowledge. With its easy-to-use website interface and customizable PDF generator, this platform offers a user-friendly experience, allowing individuals to effortlessly navigate and access the information they seek. The availability of free PDF books and manuals on this platform demonstrates its commitment to democratizing education and empowering individuals with the tools needed to succeed in their chosen fields. It allows anyone, regardless of their background or financial limitations, to expand their horizons and gain insights from experts in various disciplines. One of the most significant advantages of downloading PDF books and manuals lies in their portability. Unlike physical copies, digital books can be stored and carried on a single device, such as a tablet or smartphone, saving valuable space and weight. This convenience makes it possible for readers to have their entire library at their fingertips, whether they are commuting, traveling, or simply enjoying a lazy afternoon at home. Additionally, digital files are easily searchable, enabling readers to locate specific information within seconds. With a few keystrokes, users can search for keywords, topics, or phrases, making research and finding relevant information a breeze. This efficiency saves time and effort, streamlining the learning process and allowing individuals to focus on extracting the information they need. Furthermore, the availability of free PDF books and manuals fosters a culture of continuous learning. By removing financial barriers, more people can access educational resources and pursue lifelong learning, contributing to personal growth and professional development. This democratization of knowledge promotes

intellectual curiosity and empowers individuals to become lifelong learners, promoting progress and innovation in various fields. It is worth noting that while accessing free Repair Manual For Omc 70hp Johnson Motor PDF books and manuals is convenient and cost-effective, it is vital to respect copyright laws and intellectual property rights. Platforms offering free downloads often operate within legal boundaries, ensuring that the materials they provide are either in the public domain or authorized for distribution. By adhering to copyright laws, users can enjoy the benefits of free access to knowledge while supporting the authors and publishers who make these resources available. In conclusion, the availability of Repair Manual For Omc 70hp Johnson Motor free PDF books and manuals for download has revolutionized the way we access and consume knowledge. With just a few clicks, individuals can explore a vast collection of resources across different disciplines, all free of charge. This accessibility empowers individuals to become lifelong learners, contributing to personal growth, professional development, and the advancement of society as a whole. So why not unlock a world of knowledge today? Start exploring the vast sea of free PDF books and manuals waiting to be discovered right at your fingertips.

FAQs About Repair Manual For Omc 70hp Johnson Motor Books

1. Where can I buy Repair Manual For Omc 70hp Johnson Motor books? Bookstores: Physical bookstores like Barnes & Noble, Waterstones, and independent local stores. Online Retailers: Amazon, Book Depository, and various online bookstores offer a wide range of books in physical and digital formats.
2. What are the different book formats available? Hardcover: Sturdy and durable, usually more expensive. Paperback: Cheaper, lighter, and more portable than hardcovers. E-books: Digital books available for e-readers like Kindle or software like Apple Books, Kindle, and Google Play Books.
3. How do I choose a Repair Manual For Omc 70hp Johnson Motor book to read? Genres: Consider the genre you enjoy (fiction, non-fiction, mystery, sci-fi, etc.). Recommendations: Ask friends, join book clubs, or explore online reviews and recommendations. Author: If you like a particular author, you might enjoy more of their work.
4. How do I take care of Repair Manual For Omc 70hp Johnson Motor books? Storage: Keep them away from direct sunlight and in a dry environment. Handling: Avoid folding pages, use bookmarks, and handle them with clean hands. Cleaning: Gently dust the covers and pages occasionally.
5. Can I borrow books without buying them? Public Libraries: Local libraries offer a wide range of books for borrowing. Book Swaps: Community book exchanges or online platforms where people exchange books.
6. How can I track my reading progress or manage my book collection? Book Tracking Apps: Goodreads, LibraryThing,

and Book Catalogue are popular apps for tracking your reading progress and managing book collections. Spreadsheets: You can create your own spreadsheet to track books read, ratings, and other details.

7. What are Repair Manual For Omc 70hp Johnson Motor audiobooks, and where can I find them? Audiobooks: Audio recordings of books, perfect for listening while commuting or multitasking. Platforms: Audible, LibriVox, and Google Play Books offer a wide selection of audiobooks.
8. How do I support authors or the book industry? Buy Books: Purchase books from authors or independent bookstores. Reviews: Leave reviews on platforms like Goodreads or Amazon. Promotion: Share your favorite books on social media or recommend them to friends.
9. Are there book clubs or reading communities I can join? Local Clubs: Check for local book clubs in libraries or community centers. Online Communities: Platforms like Goodreads have virtual book clubs and discussion groups.
10. Can I read Repair Manual For Omc 70hp Johnson Motor books for free? Public Domain Books: Many classic books are available for free as they're in the public domain. Free E-books: Some websites offer free e-books legally, like Project Gutenberg or Open Library.

Find Repair Manual For Omc 70hp Johnson Motor :

sample sponsorship letter for an athlete

sample letter welcoming new board members

sample teacher appreciation letter to parents

sample question paper of cds exam

sample question paper of msbte 6th semester mechanical

sample insurance agency operations manual

sample rti schedules elementary

sample sponsor form template for cheerleading

sample measurement standards manual

sample smart goals for sixth grade science

~~sample of usher application speech~~

sample letter to excuse absence

sample exam questions on organizational behavior

sample iaat test

sample persuasive essay environmental issue

Repair Manual For Omc 70hp Johnson Motor :

[the enchanted wood by enid blyton open library](#) - Jan 28 2023

web the first magical story in the faraway tree series by one of the world s most popular children s authors enid blyton joe beth and frannie find the enchanted wood on the

the enchanted wood enid blyton free download - Oct 05 2023

web the enchanted wood gnivek volume 01 1 enid blyton fml books 1971 tags freemegalink com gnivek com jo and his two sisters bessie and

the enchanted wood enid blyton archive org - Aug 03 2023

web jul 2 2015 the enchanted wood book 1 enid blyton hachette children s group jul 2 2015 juvenile fiction 276 pages the first magical story in the faraway tree series by

the enchanted wood by enid blyton chapter 1 read aloud - Nov 13 2021

the faraway tree wikipedia - Nov 25 2022

web home contact us updated may 28 forums member login the enchanted wood book 1 of 3 in this category book details first edition 1939 publisher george newnes

the enchanted wood enid blyton google books - Mar 30 2023

web the faraway tree is a series of popular novels for children by british author enid blyton the titles in the series are the enchanted wood 1939 the magic faraway tree

[pdf epub the enchanted wood the faraway tree 1](#) - Apr 18 2022

web nov 5 2011 january 9 2009 edited by edwardbot merge author october 15 2008 created by importbot imported from talis marc record the enchanted wood by

the enchanted wood enid blyton google books - Feb 26 2023

web apr 29 2011 march 12 2010 edited by workbot merge works april 29 2008 created by an anonymous user imported from amazon com record the enchanted wood by enid

the enchanted wood book 1 enid blyton google books - Apr 30 2023

web dec 17 1997 the enchanted wood by enid blyton december 17 1997 egmont childrens books edition it looks like you re offline donate Čeština cs deutsch de

the enchanted wood by enid blyton read online on bookmate - May 20 2022

web february 28 2023 history edit an edition of the enchanted wood 1939 the enchanted wood by enid blyton 4 08 13 ratings
152 want to read 12 currently

[the enchanted wood by enid blyton open library](#) - Dec 15 2021

read the enchanted wood online free by enid blyton - Sep 04 2023

web blyton enid author publication 2014 topics children s stories friendship juvenile fiction magic juvenile fiction premier s
reading challenge n s w grades 3 4

[the enchanted wood book 1 by enid blyton google play](#) - Aug 23 2022

web sep 21 2019 before you start complete the enchanted wood the faraway tree 1 pdf epub by enid blyton download you
can read below technical ebook details full

[the enchanted wood by enid blyton waterstones](#) - Mar 18 2022

web sep 11 2020 come on a journey full of magic and adventure in the magic faraway tree when joe beth and frannie move
to a new home an enchanted wood is on

the enchanted wood by enid blyton open library - Jan 16 2022

the enchanted wood by enid blyton - Jul 22 2022

web may 8 2014 the enchanted wood is the first magical story in the faraway tree series by the world s best loved children s
author enid blyton come on a journey full of magic

the enchanted wood booktrust - Jun 20 2022

web english 247 pages 20 cm when joe beth and frannie move to the country they find a wood nearby in the wood stands the
magic faraway tree where the saucepan man

the enchanted wood the faraway tree 1 by enid - Jun 01 2023

web the enchanted wood when joe beth and frannie move to a new home an enchanted wood is on their doorstep and when
they discover the faraway tree that is the

[the enchanted wood by enid blyton open library](#) - Dec 27 2022

web the first book in enid blyton s much loved magic faraway tree series read by kate winslet the enchanted wood is the first
wonderful story in the faraway tree series

the enchanted wood blyton enid free download borrow and - Feb 14 2022

the enchanted wood by enid blyton open library - Oct 25 2022

web 21 reviews author enid blyton publisher farshore when joe beth and frannie move into a new home they discover a mysterious wood on their very doorstep soon they

the enchanted wood by enid blyton ebook ebooks com - Sep 23 2022

web the enchanted wood the enchanted wood by enid blyton published by good press good press publishes a wide range of titles that encompasses every genre from well

the enchanted wood no 1 faraway tree series blyton enid - Jul 02 2023

web the enchanted wood enid blyton egmont 2002 authors english 213 pages jo bessie and fanny move to the country and find an enchanted wood right on their

atlas copco drill rig roc d5 d7 d9 maintenance instructions - Dec 07 2022

web atlas copco drill rig roc d5 d7 d9 maintenance instructions size 5 65 mb format pdf language english brand atlas copco type of machine drill rig type of document maintenance instructions model atlas copco drill rig roc d5 d7 d9 date 2007 number of pages 107 pages part number 9852197901

atlas copco roc d7 service manual gny salvationarmy org - Dec 27 2021

web atlas copco roc d7 service manual thank you for reading atlas copco roc d7 service manual as you may know people have search numerous times for their favorite readings like this atlas copco roc d7 service manual but end up in malicious downloads rather than enjoying a good book with a cup of tea in the afternoon instead

atlas copco roc d7 service manual community moldex3d - Apr 30 2022

web atlas copco roc d7 service manual is user friendly in our digital library an online entry to it is set as public hence you can download it instantly our digital library saves in complex countries allowing you to get the most less latency epoch to

atlas copco roc d5 d7 manual pdf bomba energía y - Nov 06 2022

web atlas copco roc d5 d7 manual pdf bomba energía y recursos cados por el esquema de mantenimiento en vigor maniobra y paradas de emergencia informe inmediatamente sobre daños e incorrecciones no seguridad se encuentren montados estén limpios y sean legi lista de piezas de repuesto las disposiciones locales en

atlas copco roc d7 11 spare parts catalogue factory service manual - Sep 04 2022

web with this original factory parts manuals the technician can easily find any part number and correct part encountered in the operation of your atlas copco models of atlas copco roc d7 11 s n 8992 0052 40 download sample of this pdf manual

9852 1782 01a maintenance instructions roc d5 d7 d9 - Aug 15 2023

web atlas copco roc d5 d7 d9 maintenance instructions pm no 9852 1782 01a 2006 02 safety instructions before starting read all instructions carefully special attention must be paid to information alongside this symbol only use genuine atlas copco parts 1250 0071 04 copyright 2006 atlas copco rock drills ab sweden

atlas copco roc d7 operacion manual by i462 issuu - Jul 02 2022

web jan 20 2018 get atlas copco roc d7 operacion manual pdf file for free from our online library atlas copco roc d7 operacion manual the primary subject of this pdf is mostly covered about

116 atlas copco roc d7 handbook pdf pdf engines drill - Jun 13 2023

web 357892574 116 atlas copco roc d7 handbook pdf free download as pdf file pdf text file txt or read online for free

atlas copco roc d5 d7 d9 and d7lf - Jul 14 2023

web specifications engine compressor caterpillar turbo charged diesel engine cat c7 tier iii stage 3 power rating at 2200 rpm 168 kw 225 hp fuel consumption approx 26 l h 6 9 us gal h feed hydraulic cylinder feed with hose guide and double drill steel support with movable lower guide dust hood

atlas copco drill rig roc d5 d7 d9 maintenance instructions - May 12 2023

web atlas copco drill rig roc d5 d7 d9 maintenance instructions size 5 65 mb format pdf language english brand atlas copco type of machine drill rig type of document maintenance instructions model atlas copco drill rig roc d5 d7 d9 date 2007

number of pages 107 pages part number 9852197901

technical data roc d7 atlas copco yumpu - Oct 05 2022

web mar 8 2013 the hydraulic winch on the strong d7 strong now makes this even easier strong atlas strong strong copco strong brings you the strong roc strong strong d7 strong with more power and strength than any earlier crawler of its size strong roc strong strong d7 strong is a tophammer drill rig with the smooth

roc d7 delkom kaya delici - Mar 10 2023

web roc d7 ana uygulama alanı verimliliğin ve çevreye etkinin çok önemli olduğu agrega ocaklarıdır rock drill part service mining drilling spares turkey rock drill spare parts copsc25 he delici makina ekipmanları mb 1000 kirici yedek parçaları ec 70 hidrolik kirici speedroc2fa cop rr11 atlas copco delik dibi tabancalar

atlas copco roc d7 youtube - Feb 26 2022

web drilling for blasting for a road construction first time blasting in this quarry komatsu pc228 us lc in the background 2011 07 05

atlas copco roc d7 c construction equipment - Mar 30 2022

web the roc d7 c a computerized surface crawler drills straight holes quickly and accurately it features a system that adds rods into the drill string automatically increasing

forside hso - Jun 01 2022

web atlas copco surface drill rigs roc d5 d7 d9 technical specification and roc d7 d7lf atlas cc a true workhorse for the widest range of applications unique durable cylinder operated feed system that makes the best use of the rock drill long reach

makes it ideal for use also in slope stabilization

atlas copco roc d7 11 spare parts catalogue factory service manual - Aug 03 2022

web atlas copco roc d7 11 spare parts catalogue download 3 file size 39 mb enter correct password to download your download link is ready processing product code ats 0001 if you already purchase this product please check your dashboard for download password

download the manual atlas copco - Apr 11 2023

web download the manual below you find the distributor manual for donwload in different languages atlas copco brand identity manual for distributors arabic atlas copco brand identity manual for distributors chinese atlas copco brand identity manual for distributors english

atlas copco drill rig roc d5 d7 d9 maintenance instructions - Feb 09 2023

web oct 26 2020 atlas copco drill rig roc d5 d7 d9 maintenance instructions size 5 65 mb format pdf language english brand atlas copco type of machine drill rig

atlas copco roc d7 service manual 2022 mcf strathmore - Jan 28 2022

web atlas copco roc d7 service manual downloaded from mcf strathmore edu by guest cameron stephenson sacred hymns and spiritual songs for the church of jesus christ of latter day saints wiley interscience the five volumes of the international directory of company histories bring together histories of the leading companies of the

atlas copco roc d5 d7 d9 and d7lf ee industry equipment - Jan 08 2023

web atlas copco surface drill rigs roc d5 d7 d9 and d7lf technical specification unique durable cylinder operated feed system that makes the best use of the rock drill long reach makes it ideal for use also in slope stabilization

gate pass format for goods sample free download - Oct 10 2023

web gate pass is a compulsory document for companies factories and offices to bring goods in and take goods out of the premises four gate passes templates available and can be used within the factory or office as internal gate passes outside to move goods items and transport gate passes for vehicles some well known gate pass terms are inward

employee outgoing gatepass sample format pdf scribd - Feb 02 2023

web employee outgoing gatepass sample format free download as word doc doc pdf file pdf text file txt or read online for free a sample employee outgoing gate pass format

gate pass for material outgoing letter 4 example gate pass - Aug 08 2023

web nov 7 2022 material gate pass format fill and sign printable template online as ampere result in order to get through the gate without any problems i ll need adenine gate pass signed by you please issue own a gate pass as soon because possible so that myself allowed continue employed

[get the free returnable gate pass format pdffiller](#) - Apr 23 2022

web the purpose of a returnable gate pass format is to regulate and document the movement of goods or materials within a specific premises or location it serves as an official authorization that allows the entry or exit of goods or materials through a

material out gate pass format citehr - Sep 28 2022

web advance search feature available downloads page 1 gate pass format xls size 23040 k out going gate pass doc size 25088 k out going gate pass doc size 29696 k gate pass form biometric doc size 29696 k format for material inward register doc size 38400 k format for material outward register doc size 38912 k

gate pass format fill out sign online dochub - Jul 27 2022

web 01 edit your material gate pass format in word online type text add images blackout confidential details add comments highlights and more 02 sign it in a few clicks draw your signature type it upload its image or use your mobile device as a signature pad 03 share your form with others

gate pass format fill out and sign printable pdf template - Jun 25 2022

web quick steps to complete and esign gate pass format online use get form or simply click on the template preview to open it in the editor start completing the fillable fields and carefully type in required information use the cross or check marks in the top toolbar to select your answers in the list boxes

[gate pass for material outgoing letter 4 example all application](#) - Sep 09 2023

web nov 7 2022 your queries regarding gate pass for material outgoing letter is answered in this article so read this article carefully till the end to avoid any confusion example 1 gate pass for material outgoing letter format

gate pass format fill out and sign printable pdf template - Mar 23 2022

web quick steps to complete and e sign returnable gate pass format word online use get form or simply click on the template preview to open it in the editor

material gate pass pdf scribd - Apr 04 2023

web material gate pass free download as excel spreadsheet xls pdf file pdf text file txt or read online for free this is document use for material gate pass

gate pass for material outgoing letter 4 example gate pass - Nov 30 2022

web nov 7 2022 your faqs regarding gate pass for material outgoing letter belongs answered in this article so show this news carefully till the exit to avoidances any confusion example 1 gate pass for material outgoing mailing format

get material gate pass format in word download us legal - Feb 19 2022

web material out gate pass format in word rating 4.8 satisfied 37 votes tips on how to fill out edit and sign outward gate pass format in word online how to fill and sign gate pass format word how to edit get pass format how to fill out and sign gate pass

sample for materials online

get material gate pass format us legal forms - May 25 2022

web material gate pass format get material gate pass format how it works open form follow the instructions easily sign the form with your finger send filled signed form or save gate pass format excel rating 4 8 satisfied 47 votes how to fill out and sign gate pass format in excel online

pdf gate pass format download pdf word excel - Jun 06 2023

web there are many types of gate passes such as for material visitor vehicle format for incoming outgoing items vehicles with meter reading employee lockdown etc we are sharing all available gate pass format which all are downloadable and you can access from the given link below

material outward gatepass workflowaxis gatepass - Oct 30 2022

web axis gatepass contains a comprehensive module for returnable nonreturnable material outward gatepass rgp nrgp workflow following are salient features of this module based on the approval policy a custom approval workflow can be defined as soon as a material outward request is entered in the system email alerts are sent to the approvers

gate pass authorization for taking out material for outsiders - Aug 28 2022

web nov 30 2012 gate pass authorization for taking out material for outsiders download as a pdf or view online for free

material gate pass touch point - Mar 03 2023

web enjoy the automated dynamic pass facility with our material gate pass management system depending on the material department etc easily define the required information format and template for the passes it is no more a hassle to define the inter office passes

material gate pass at in word doc template pdfiller - Jan 01 2023

web a material gate pass format is a document that is used to record the movement of materials in and out of a facility it typically includes information such as the date of the transaction the item being transported the quantity the name of the person receiving the material and any other relevant details

gate pass format for employees sample gate pass format - Jul 07 2023

web jan 12 2023 you can use the gate pass format to track all company activities track the number of people coming and departing your workplace print id cards visitor gate passes and material passes record vehicle and driver data and more

gate pass format fill out and sign printable pdf template - May 05 2023

web use its powerful functionality with a simple to use intuitive interface to fill out material gate pass format in word online esign them and quickly share them without jumping tabs follow our step by step guide on how to do paperwork without the paper

