

ELECTRICAL
1996 Wiring Diagram - Indy 440 LC / Trail / Trail Touring / 500 Carb, SKS, RMK / Classic / Classic Touring

96 500 CARB, SKS, RMK
 TRAIL TOURING
 440 L/C
 CLASSIC
 TRAIL

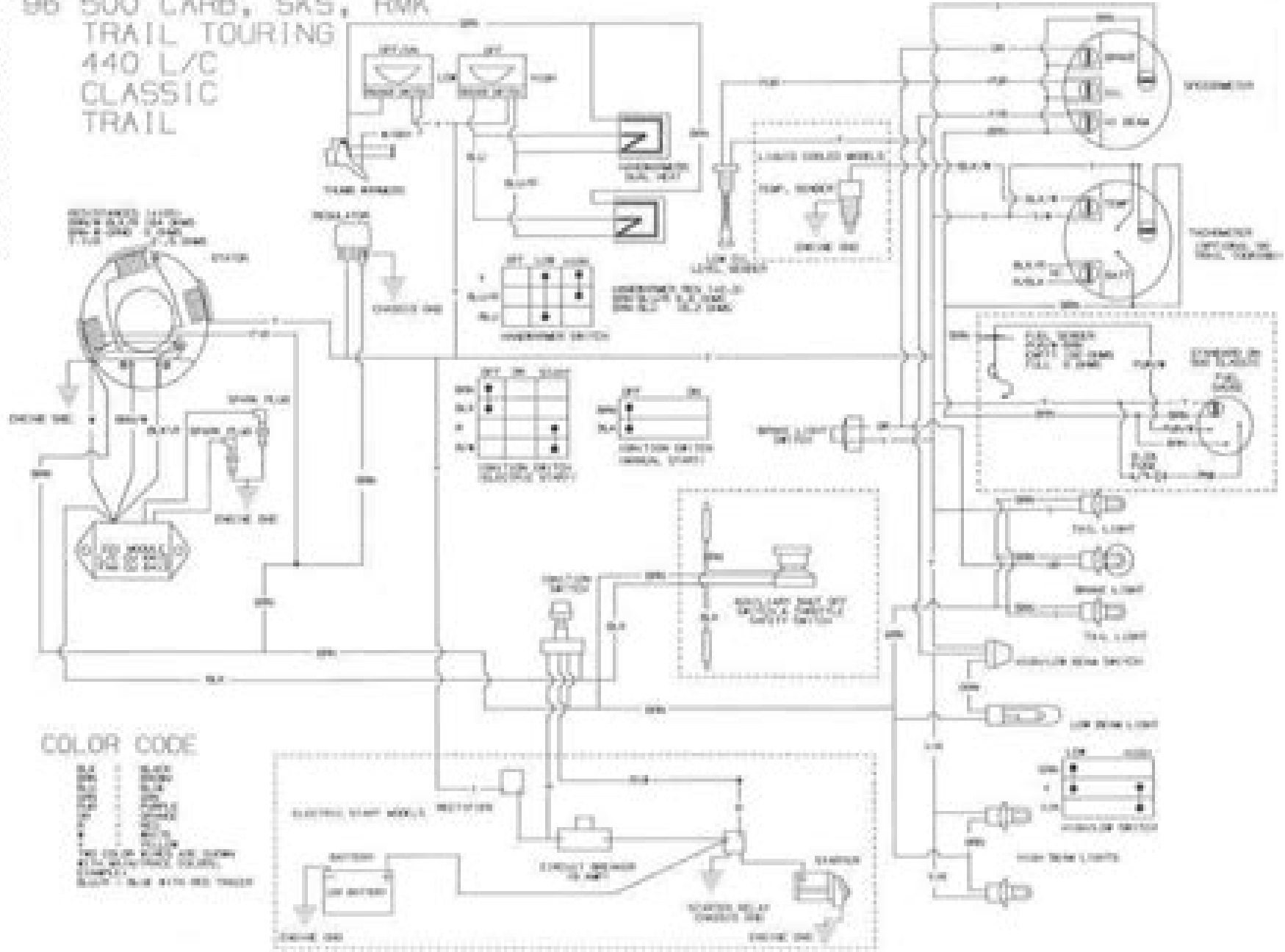

Polaris Sportsman Atv 60and 70wiring Diagram

SA Adler



Polaris Sportsman Atv 60and 70wiring Diagram:

As recognized, adventure as with ease as experience about lesson, amusement, as competently as treaty can be gotten by just checking out a book **Polaris Sportsman Atv 60and 70wiring Diagram** with it is not directly done, you could recognize even more just about this life, roughly speaking the world.

We meet the expense of you this proper as competently as simple way to get those all. We have the funds for Polaris Sportsman Atv 60and 70wiring Diagram and numerous book collections from fictions to scientific research in any way. accompanied by them is this Polaris Sportsman Atv 60and 70wiring Diagram that can be your partner.

<https://crm.avenza.com/results/uploaded-files/default.aspx/Official%20Chevrolet%20S%2010%20Owners%20Manual.pdf>

Table of Contents Polaris Sportsman Atv 60and 70wiring Diagram

1. Understanding the eBook Polaris Sportsman Atv 60and 70wiring Diagram
 - The Rise of Digital Reading Polaris Sportsman Atv 60and 70wiring Diagram
 - Advantages of eBooks Over Traditional Books
2. Identifying Polaris Sportsman Atv 60and 70wiring Diagram
 - Exploring Different Genres
 - Considering Fiction vs. Non-Fiction
 - Determining Your Reading Goals
3. Choosing the Right eBook Platform
 - Popular eBook Platforms
 - Features to Look for in an Polaris Sportsman Atv 60and 70wiring Diagram
 - User-Friendly Interface
4. Exploring eBook Recommendations from Polaris Sportsman Atv 60and 70wiring Diagram
 - Personalized Recommendations
 - Polaris Sportsman Atv 60and 70wiring Diagram User Reviews and Ratings
 - Polaris Sportsman Atv 60and 70wiring Diagram and Bestseller Lists
5. Accessing Polaris Sportsman Atv 60and 70wiring Diagram Free and Paid eBooks

- Polaris Sportsman Atv 60and 70wiring Diagram Public Domain eBooks
 - Polaris Sportsman Atv 60and 70wiring Diagram eBook Subscription Services
 - Polaris Sportsman Atv 60and 70wiring Diagram Budget-Friendly Options
6. Navigating Polaris Sportsman Atv 60and 70wiring Diagram eBook Formats
 - ePub, PDF, MOBI, and More
 - Polaris Sportsman Atv 60and 70wiring Diagram Compatibility with Devices
 - Polaris Sportsman Atv 60and 70wiring Diagram Enhanced eBook Features
 7. Enhancing Your Reading Experience
 - Adjustable Fonts and Text Sizes of Polaris Sportsman Atv 60and 70wiring Diagram
 - Highlighting and Note-Taking Polaris Sportsman Atv 60and 70wiring Diagram
 - Interactive Elements Polaris Sportsman Atv 60and 70wiring Diagram
 8. Staying Engaged with Polaris Sportsman Atv 60and 70wiring Diagram
 - Joining Online Reading Communities
 - Participating in Virtual Book Clubs
 - Following Authors and Publishers Polaris Sportsman Atv 60and 70wiring Diagram
 9. Balancing eBooks and Physical Books Polaris Sportsman Atv 60and 70wiring Diagram
 - Benefits of a Digital Library
 - Creating a Diverse Reading Collection Polaris Sportsman Atv 60and 70wiring Diagram
 10. Overcoming Reading Challenges
 - Dealing with Digital Eye Strain
 - Minimizing Distractions
 - Managing Screen Time
 11. Cultivating a Reading Routine Polaris Sportsman Atv 60and 70wiring Diagram
 - Setting Reading Goals Polaris Sportsman Atv 60and 70wiring Diagram
 - Carving Out Dedicated Reading Time
 12. Sourcing Reliable Information of Polaris Sportsman Atv 60and 70wiring Diagram
 - Fact-Checking eBook Content of Polaris Sportsman Atv 60and 70wiring Diagram
 - Distinguishing Credible Sources
 13. Promoting Lifelong Learning
 - Utilizing eBooks for Skill Development

- Exploring Educational eBooks
14. Embracing eBook Trends
- Integration of Multimedia Elements
 - Interactive and Gamified eBooks

Polaris Sportsman Atv 60and 70wiring Diagram Introduction

Polaris Sportsman Atv 60and 70wiring Diagram Offers over 60,000 free eBooks, including many classics that are in the public domain. Open Library: Provides access to over 1 million free eBooks, including classic literature and contemporary works. Polaris Sportsman Atv 60and 70wiring Diagram Offers a vast collection of books, some of which are available for free as PDF downloads, particularly older books in the public domain. Polaris Sportsman Atv 60and 70wiring Diagram : This website hosts a vast collection of scientific articles, books, and textbooks. While it operates in a legal gray area due to copyright issues, its a popular resource for finding various publications. Internet Archive for Polaris Sportsman Atv 60and 70wiring Diagram : Has an extensive collection of digital content, including books, articles, videos, and more. It has a massive library of free downloadable books. Free-eBooks Polaris Sportsman Atv 60and 70wiring Diagram Offers a diverse range of free eBooks across various genres. Polaris Sportsman Atv 60and 70wiring Diagram Focuses mainly on educational books, textbooks, and business books. It offers free PDF downloads for educational purposes. Polaris Sportsman Atv 60and 70wiring Diagram Provides a large selection of free eBooks in different genres, which are available for download in various formats, including PDF. Finding specific Polaris Sportsman Atv 60and 70wiring Diagram, especially related to Polaris Sportsman Atv 60and 70wiring Diagram, might be challenging as theyre often artistic creations rather than practical blueprints. However, you can explore the following steps to search for or create your own Online Searches: Look for websites, forums, or blogs dedicated to Polaris Sportsman Atv 60and 70wiring Diagram, Sometimes enthusiasts share their designs or concepts in PDF format. Books and Magazines Some Polaris Sportsman Atv 60and 70wiring Diagram books or magazines might include. Look for these in online stores or libraries. Remember that while Polaris Sportsman Atv 60and 70wiring Diagram, sharing copyrighted material without permission is not legal. Always ensure youre either creating your own or obtaining them from legitimate sources that allow sharing and downloading. Library Check if your local library offers eBook lending services. Many libraries have digital catalogs where you can borrow Polaris Sportsman Atv 60and 70wiring Diagram eBooks for free, including popular titles. Online Retailers: Websites like Amazon, Google Books, or Apple Books often sell eBooks. Sometimes, authors or publishers offer promotions or free periods for certain books. Authors Website Occasionally, authors provide excerpts or short stories for free on their websites. While this might not be the Polaris Sportsman Atv 60and 70wiring Diagram full book , it can give you a taste of the authors writing style. Subscription Services

Platforms like Kindle Unlimited or Scribd offer subscription-based access to a wide range of Polaris Sportsman Atv 60and 70wiring Diagram eBooks, including some popular titles.

FAQs About Polaris Sportsman Atv 60and 70wiring Diagram Books

What is a Polaris Sportsman Atv 60and 70wiring Diagram PDF? A PDF (Portable Document Format) is a file format developed by Adobe that preserves the layout and formatting of a document, regardless of the software, hardware, or operating system used to view or print it. **How do I create a Polaris Sportsman Atv 60and 70wiring Diagram PDF?** There are several ways to create a PDF: Use software like Adobe Acrobat, Microsoft Word, or Google Docs, which often have built-in PDF creation tools. Print to PDF: Many applications and operating systems have a "Print to PDF" option that allows you to save a document as a PDF file instead of printing it on paper. Online converters: There are various online tools that can convert different file types to PDF. **How do I edit a Polaris Sportsman Atv 60and 70wiring Diagram PDF?** Editing a PDF can be done with software like Adobe Acrobat, which allows direct editing of text, images, and other elements within the PDF. Some free tools, like PDFescape or Smallpdf, also offer basic editing capabilities. **How do I convert a Polaris Sportsman Atv 60and 70wiring Diagram PDF to another file format?** There are multiple ways to convert a PDF to another format: Use online converters like Smallpdf, Zamzar, or Adobe Acrobats export feature to convert PDFs to formats like Word, Excel, JPEG, etc. Software like Adobe Acrobat, Microsoft Word, or other PDF editors may have options to export or save PDFs in different formats. **How do I password-protect a Polaris Sportsman Atv 60and 70wiring Diagram PDF?** Most PDF editing software allows you to add password protection. In Adobe Acrobat, for instance, you can go to "File" -> "Properties" -> "Security" to set a password to restrict access or editing capabilities. Are there any free alternatives to Adobe Acrobat for working with PDFs? Yes, there are many free alternatives for working with PDFs, such as: LibreOffice: Offers PDF editing features. PDFsam: Allows splitting, merging, and editing PDFs. Foxit Reader: Provides basic PDF viewing and editing capabilities. How do I compress a PDF file? You can use online tools like Smallpdf, ILovePDF, or desktop software like Adobe Acrobat to compress PDF files without significant quality loss. Compression reduces the file size, making it easier to share and download. Can I fill out forms in a PDF file? Yes, most PDF viewers/editors like Adobe Acrobat, Preview (on Mac), or various online tools allow you to fill out forms in PDF files by selecting text fields and entering information. Are there any restrictions when working with PDFs? Some PDFs might have restrictions set by their creator, such as password protection, editing restrictions, or print restrictions. Breaking these restrictions might require specific software or tools, which may or may not be legal depending on the circumstances and local laws.

Find Polaris Sportsman Atv 60and 70wiring Diagram :

[official chevrolet s 10 owners manual](#)

office 36enterprise deployment guide

office 2007 essentials lab manual

[ocr gateway past papers 22](#)

oem rs 82 speakers owners manual

ofl unit 2 english 3 packet answers

ocr mei cjune 2exam paper

odysseyware semester 2 geometry quiz answers

odyssey spanish 2 answers

officejet 6500 maintenance manual

[ocr maths gcse june 2013 mark scheme](#)

[october november 2014 12 paper 1](#)

office 2007 missing manual

official precious moments collectors guide

office rhymes volume english edition

Polaris Sportsman Atv 60and 70wiring Diagram :

international corporate finance by madura jeff - Jan 07 2023

web international finance foreign exchange asset liability management banks and banking international international

business enterprises finance finances internationales

[jeff madura international corporate finance 8th edition](#) - Nov 24 2021

international corporate finance 8th edition by jeff madura - May 11 2023

web descriptions this text combines a strong foundation in international finance theory with current practical applications it provides thorough up to date treatment of cutting edge

international financial management jeff madura google books - Oct 04 2022

web jul 26 2023 jeff madura international corporate finance 8th edition is available in our digital library an online access to it is set as public so you can download it instantly our

[international financial management jeff madura google books](#) - Aug 02 2022

web oct 7 2011 this edition highlights financial reform and its impact on the international finance today an emphasis on the most recent financial changes and industry trends

international financial management madura jeff free - Sep 03 2022

web oct 3 2012 this book discusses a wide range of managerial topics using a strong corporate perspective this edition highlights financial reform and its impact on the

jeff madura international corporate finance 8th edition pdf - May 31 2022

web discover and share books you love on goodreads

[international corporate finance amazon co uk](#) - Apr 10 2023

web international financial management international financial management combines a strong foundation in international finance theory with current practical applications

international corporate finance madura jeff free download - Jul 13 2023

web topics international finance foreign exchange asset liability management banks and banking international international business enterprises finance

international financial management jeff madura google books - Mar 29 2022

web jeff madura international corporate finance 8th edition and numerous books collections from fictions to scientific research in any way accompanied by them is this jeff madura

loading interface goodreads - Jan 27 2022

web 2 international financial management by jeff madura solution 8th edition 2022 12 23 textbook with optional online comprehensive practice tests only cram101 is textbook

international financial management jeff madura google books - Dec 06 2022

web sep 24 2007 cengage learning sep 24 2007 business economics 704 pages international financial management strives to build on the foundation of

international financial management - Feb 25 2022

web find international corporate finance by madura jeff at biblio uncommonly good collectible and rare books from uncommonly good booksellers international

international financial management 13th edition - Mar 09 2023

web jan 23 2020 international financial management jeff madura cengage learning jan 23 2020 business economics 736 pages gain an understanding of theory and

international corporate finance jeff madura google books - Jun 12 2023

web this edition builds on the fundamental principles of corporate finance to provide the timely information and contemporary insights your students need to prosper in today s global

international corporate finance by madura jeff biblio - Oct 24 2021

international financial management 11th edition amazon com - Apr 29 2022

web feb 2 2020 product details about the author jeff madura is presently emeritus professor of finance at florida atlantic university he has written several successful finance texts

international corporate finance jeff madura google books - Aug 14 2023

web jeff madura south western 2010 corporations 709 pages international financial management builds on fundamental principles of corporate finance to

international financial management madura jeff free - Feb 08 2023

web cengage learning sep 25 2009 business economics 752 pages international financial management tenth edition builds on fundamental principles of

international financial management edition 14 by jeff madura - Dec 26 2021

web sep 8 2023 this jeff madura international corporate finance 18th edition as one of the most operational sellers here will entirely be in the middle of the best options to

international financial management jeff madura google books - Jul 01 2022

web part 1 the international financial environment 1 1 multinational financial management an overview 2 2 international flow of funds 22 3 international financial markets 50

international financial management by jeff madura solution 8th - Sep 22 2021

[access free jeff madura international corporate finance 18th](#) - Aug 22 2021

study guide for madura s international financial - Nov 05 2022

web dec 5 2016 international financial management jeff madura cengage learning dec 5 2016 business economics 752 pages delivering unrivaled depth of theory and

[grade 11 november 2020 agricultural sciences p1 marking guideline exemplar](#) - Mar 10 2023

web agricultural sciences p1 marking guideline exemplar marks 150 this marking guideline consists of 9 pages section a question 1 1 1 1 1 1 1 2 1 1 3 1 1 4 1 1 5 1 1 6 1 1 7 1 1 8 1 1 9 1 1 10 99 99 99 99 99 99 99 99 99 99 10 x 2 20 1 2 1 2 1 1 2 2 1 2 3 1 2 4 1 2 5 only 99 only 99 none 99

11 sınıf coğrafya ders notlari tarim ve - Dec 07 2022

web 11 sınıf coğrafya ders notlari tarim ve hayvancilik c yađli bitkiler 1 zeytin sıcaklığın 0 derecenin üzerinde olduđu akdeniz iklim şartlarına uyar zeytin bir yıl ürün verir diđer yıl ürün vermez bu yüzden üretimi dalgalıdır Ülkemizde sırasıyla en fazla ege marmara akdeniz ve güney

provincial assessment grade 11 north west - Jun 01 2022

web grade 11 agricultural sciences p1 november 2019 agricultural sciences paper 1 grade 11 question number bloom s taxonomy knowledge aims objectives l skills types of questions use a tick 1 only tick on phs hs pl ngs ons ng a g o a s b ry 1 2 nt s nt d ns ous ge section a

basic agricultural chemistry grade 11 basic chemistry pdf prof - Oct 05 2022

web nov 11 2012 pdf grade 11 november 2020 agricultural sciences p1 grade 11 november 2020 agricultural sciences p1 exemplar marks 150 time 2½ hours this question paper consists of 14 pages

provincial assessment grade 11 english first - May 12 2023

web november marks 150 time 2 ½ hours this question paper consists of 10 pages and 1 data sheet provincial assessment english first additional language november 2011 grade 11 agricultural sciences p1 2019

grade 11 november 2012 agricultural sciences p1 - Feb 09 2023

web nov 11 2012 2012 11 01 agricultural sciences grade 11 altus strydom 2012 09 17 study master agricultural sciences grade 11 has been especially developed by an experienced author team for the curriculum and assessment policy statement caps this new and easy to use course helps learners to master essential content and skills in

agricultural sciences p1 nov 2017 memo eng studocu - Feb 26 2022

web nov 1 2017 this is the agricultural sciences national senior certificate november paper 1 2017 exam memorandum national senior certificate grade 12 agricultural sciences

november 2012 gr 11 exams examinations - Jun 13 2023

web november 2012 gr 11 exams home l feedback date subject memo subject memo monday 22 october agricultural sciences p1 landbouwetenskappe v1 memo memo isixhosa home language p3 isixhosa first additional language p3 sesotho home language p3 memo memo memo tuesday 23 october history p1 addendum

grade 11 november 2012 agricultural sciences p1 - Aug 15 2023

web grade 11 november 2012 agricultural sciences p1 marks 150 time 2 1/2 hours agrse1 this question paper consists of 17 pages including an answer sheet instructions and information answer all the questions from both sections a and b section a question 1 must be answered on the attached answer sheet

grade 11 november 2018 agricultural sciences p1 - Jul 02 2022

web nov 11 2018 grade 11 november 2018 agricultural sciences p1 marks 150 time 2 1/2 hours this question paper consists of 16 pages instructions and information answer all the questions in the answer book start each question on a new page read all the questions correctly and answer only what is asked

grade 11 november 2022 agricultural sciences p1 - Mar 30 2022

web nov 11 2022 agricultural sciences p1 marking guideline marks 150 this marking guideline consists of 9 pages section a question 1 1 1 1 1 1 1 2 1 1 3 1 1 4 1 1 5 1 1 6 1 1 7 1 1 8 1 1 9 1 1 10 10 x 2 20 1 2 1 2 1 1 2 2 1 2 3 1 2 4 1 2 5 1 3 1 3 1 1 3 2 1 3 3 1 3 4 1 3 5 1 4 1 4 1

grade 11 november 2013 agricultural sciences p1 - Apr 30 2022

web grade 11 november 2013 agricultural sciences p1 marks 150 time 2 1/2 hours this question paper consists of 14 pages including an answer sheet

national senior certificate grade 12 national - Sep 04 2022

web feb 5 2013 a quarantine services to prevent diseases or pests being brought into the country

grade 11 november 2020 agricultural sciences p1 exemplar - Jan 08 2023

web grade 11 november 2020 agricultural sciences p1 exemplar marks 150 time 2 1/2 hours this question paper consists of 14 pages 2 agricultural sciences p1 ec november 2020 copyright reserved please turn over instructions and information 1 answer all the questions in the answer book 2 start each

agricultural sciences grade 11 exam papers and memos 2023 - Aug 03 2022

web may 15 2023 agricultural sciences grade 11 exam papers and memos for 2023 can be downloaded below these papers and memos are essential for any grade 11 agricultural sciences student as they provide valuable practice for the upcoming exams agr sciences p2 memo gr11 nov 2019 afrikaans pdf agr sciences p2 memo

grade11november2012agriculturalsciencesp1 download only - Nov 06 2022

web grade 11 november 2012 agricultural sciences p1 memorandum 4 agricultural sciences p1 memo november 2012 2 4 matter is anything that has mass and takes up space atoms are the basic units or the building block of all matter 4 agricultural sciences grade 11 past papers and memos for 2019 hello grade 11 learners modern classroom has

2012 nsc examinations national department of basic education - Apr 11 2023

web national curriculum statements grades r 12 2012 nsc examinations agricultural sciences english p1 memo download agricultural sciences english p2 download agricultural sciences english p2 memo download agricultural technology title agricultural technology afrikaans

grade 11 november 2012 agricultural sciences p1 - Jul 14 2023

web 6 agricultural sciences p1 memo november 2012 question 4 soil science 4 1 4 1 1 a transpiration transpiration losses b

soil surface evaporation c run of storm water erosion d seepage percolation saturated flow leaching 4 4 1 2 controlled irrigation addition of organic matter

updated cbse class 11 agriculture syllabus 2023 24 in pdf - Jan 28 2022

web may 22 2023 class 11 agriculture syllabus check out the latest cbse ncert class 11 agriculture syllabus the syllabus is for the academic year 2023 24 sessions first of all check the cbse class 11 agriculture exam pattern students are advised to check out the complete syllabus and exam pattern with the marking scheme

syllabus cbse class 11th 12th agriculture syllabus 2011 code - Dec 27 2021

web class 11th 12th agriculture code no 068 class xi theory importance of livestock in agriculture and industry white revolution in india b important breeds indian and exotic distribution of cows buffaloes and poultry in india 13 the soil science by t d biswas and s k mukherjee tata mcgraw hill pub co ltd new delhi

learning outdoors with the meek family by tim meek used - Mar 26 2023

web buy learning outdoors with the meek family by tim meek available in used condition with free delivery in the uk isbn 9780711236950 isbn 10 071123695x

learning outdoors with the meek family amazon co uk - Jul 30 2023

web education does not always need to take place behind a desk in a classroom or with a teacher family time is just as important as school time and these 52 ed ventures provide parents with a fantastic bank of ideas to support and

learning outdoors with the meek family mail lafamigliawv - Feb 10 2022

web the third book from the meek family 50 evening adventures encourages families to make the most of their 5 to 9 those evening hours after school and after work here are simple and exciting ideas for spending time together out of doors during the working week

learning outdoors with the meek family pdf epub download - Aug 31 2023

web learning outdoors with the meek family book in pdf epub and kindle version is available to download in english read online anytime anywhere directly from your device click on the download button below to get a free pdf file of learning outdoors with the meek family book

learning outdoors with the meek family tom howey - Oct 21 2022

web illustrations for children s book learning outdoors with the meek family published 2015 by frances lincoln

learning outdoors with the meek family by tim meek is - Jul 18 2022

web back to learning outdoors with the meek family find a digital library with learning outdoors with the meek family near you search by city zip code or library name search learn more about precise location detection showing public libraries k 12 schools library name distance show all our apps libby sora kanopy

learning outdoors with the meek family 52 family ed - May 16 2022

web learning outdoors with the meek family 52 family ed ventures the meek family the blakesley miniature railway and the bartholomew family railway heritage dr

learning outdoors with the meek family apple books - Feb 22 2023

web aug 27 2015 whether you re visiting a wind farm or stepping on to a train visiting an historical building or looking at a sculpture in your local park learning outdoors provides all the educational stimulation you and your children

learning outdoors with the meek family overdrive - Jan 24 2023

web aug 27 2015 learning outdoors with the meek family ebook by tim meek read a sample format ebook isbn 9780711236950 author tim meek publisher frances lincoln release 27 august 2015 subjects history reference science nonfiction find this title in libby the library reading app by overdrive search for a digital library with this title

learning outdoors with the meek family open library - Apr 26 2023

web learning outdoors with the meek family by meek family 2015 frances lincoln limited edition in english first frances lincoln limited edition

our best ever family decision quitting school and jobs and - Jun 16 2022

web jan 30 2016 the meek family swapped mortgage work and school for a year of adventures around the uk their home a caravan their classroom the great outdoors

learning outdoors with the meek family kerry meek - Nov 21 2022

web whether you re visiting a wind farm or stepping on to a train visiting an historical building or looking at a sculpture in your local park learning outdoors provides all the educational stimulation you and your children need for some great ed ventures in the open air author meek tim author meek kerry publisher frances lincoln

learning outdoors with the meek family kindle edition - Aug 19 2022

web aug 27 2015 learning outdoors with the meek family kindle edition by meek tim meek kerry download it once and read it on your kindle device pc phones or tablets use features like bookmarks note taking and highlighting while reading learning outdoors with the meek family

learning outdoors with the meek family google books - May 28 2023

web within each activity there is plenty of scope to help your children develop enquiring minds including ideas on what to do before you get there while you re there and when you get back plus

learning outdoors with the meek family google books - Jun 28 2023

web within each activity there is plenty of scope to help your children develop enquiring minds including ideas on what to do before you get there while you re there and when you get back plus tips

learning outdoors with the meek family by meek tim meek - Mar 14 2022

web learning outdoors with the meek family by meek tim meek kerry in used like 8 88 for sale learning outdoors with the meek family isbn 9780711236950 title 123680374518

learning outdoors with the meek family bookmate - Apr 14 2022

web read learning outdoors with the meek family by kerry meek tim meek online on bookmate education does not always need to take place behind a desk in a classroom or with a teacher read in our apps ios android kerry meek tim meek learning outdoors with the meek family notify me when the book s added impression add to

learning outdoors with the meek family paperback tim meek - Sep 19 2022

web aug 16 2023 find many great new used options and get the best deals for learning outdoors with the meek family paperback tim meek kerry at the best online prices at ebay free delivery for many products

learning outdoors with the meek family softcover abebooks - Dec 23 2022

web learning outdoors with the meek family by meek tim meek kerry isbn 10 071123695x isbn 13 9780711236950 frances lincoln 2015 softcover

learning outdoors with the meek family meek family meek - Oct 01 2023

web 52 family ed ventures cover tim kerry amy and ella meek spine buildings to see places to go travel and transport by the water country life culture and entertainment