

## INTRODUCTION

Thank you for your purchase of the SL33 Stereo Program Limiter. This device provides smooth dynamics processing for mainly consumer-level equipment. Since there is no audio level standard for consumer audio equipment, the SL33 keeps the levels maintained for a more comfortable listening environment.

## WARRANTY

For complete information on the Rolls 1 Year Warranty, and to register this product, see our website at [www.rolls.com](http://www.rolls.com).

## DESCRIPTION



### FRONT PANEL

**Makeup Gain:** This control varies the amount of post-compressor circuit gain. Essentially, this acts as an output level control.  
**Threshold:** This control sets the level at which compression begins.

### REAR PANEL

**INPUTS:** R, L and R/L; 1/4" Tip-Ring-Sleeve balanced and RCA unbalanced input jacks.  
**OUTPUTS:** R, L and R/L; 1/4" Tip-Ring-Sleeve balanced and RCA unbalanced output jacks.  
**12 VDC:** Connects to the included Rolls model PS27 12 VDC power supply.

## SCHEMATIC

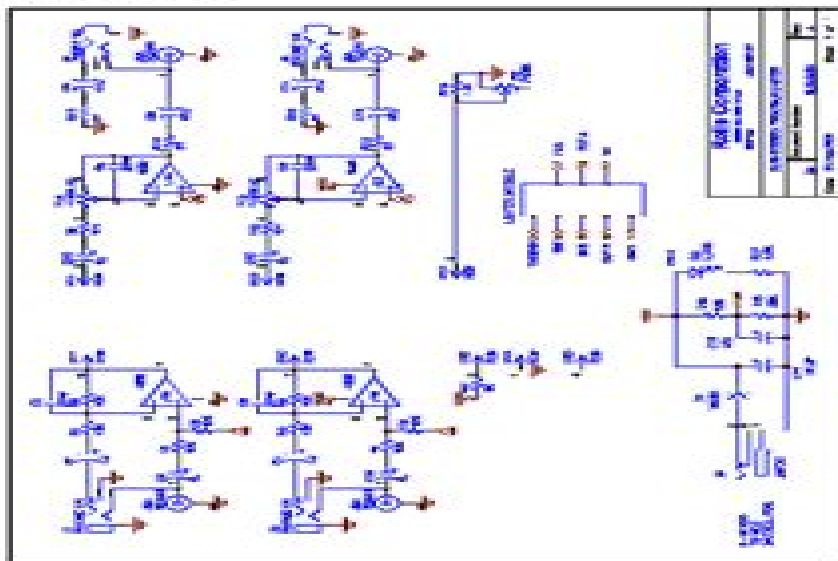

... anywhere you need smooth compression of consumer program material.

# ROLLS

- Restaurant
- Night Club
- School/Church

## SL33 Stereo Program Limiter

## SL33 Stereo Program Limiter

# ROLLS

## SL33 Stereo Program Limiter

The SL33 acts as an audio program material leveler for mainly consumer audio. It helps control the level over loud, obnoxious commercials for example.

- Stereo Compressor/Limiter
- 1/4" Balanced / RCA unbalanced Inputs and Outputs
- Automatic program limiting
- Output Level control
- Threshold control

## SPECIFICATIONS

Inputs: 1/4" TRS balanced, RCA unbalanced  
Outputs: 1/4" TRS balanced, RCA unbalanced  
Compression Ratio: Program dependent  
Threshold: Variable; -13 to +6 dB  
Input Impedance: 10K Ohms bal/unbal  
Output Impedance: 50 Ohms bal/unbal  
Max Output Level: +13 dBV  
Power: 12 VDC, 50 mA  
Dimensions: 4" x 3.35" x 1.5" (W x H x D)  
Weight: 1 lb.

CE



Rolls Corporation,  
Salt Lake City, UT  
8/08

# ROLLS

SL33 Stereo Limiter



6 75889 00033 7

# Rolls SI33 Owners Manual

**VM Jensen**



## **Rolls SI33 Owners Manual:**

Getting the books **Rolls SI33 Owners Manual** now is not type of challenging means. You could not abandoned going taking into consideration books gathering or library or borrowing from your connections to right of entry them. This is an extremely simple means to specifically get lead by on-line. This online pronouncement Rolls SI33 Owners Manual can be one of the options to accompany you like having new time.

It will not waste your time. put up with me, the e-book will utterly aerate you supplementary thing to read. Just invest little era to gate this on-line broadcast **Rolls SI33 Owners Manual** as with ease as evaluation them wherever you are now.

[https://crm.avenza.com/results/uploaded-files/index.jsp/Sepedi\\_Home\\_Laguage\\_June\\_Exam\\_Pmemo\\_Grade11.pdf](https://crm.avenza.com/results/uploaded-files/index.jsp/Sepedi_Home_Laguage_June_Exam_Pmemo_Grade11.pdf)

## **Table of Contents Rolls SI33 Owners Manual**

1. Understanding the eBook Rolls SI33 Owners Manual
  - The Rise of Digital Reading Rolls SI33 Owners Manual
  - Advantages of eBooks Over Traditional Books
2. Identifying Rolls SI33 Owners Manual
  - Exploring Different Genres
  - Considering Fiction vs. Non-Fiction
  - Determining Your Reading Goals
3. Choosing the Right eBook Platform
  - Popular eBook Platforms
  - Features to Look for in an Rolls SI33 Owners Manual
  - User-Friendly Interface
4. Exploring eBook Recommendations from Rolls SI33 Owners Manual
  - Personalized Recommendations
  - Rolls SI33 Owners Manual User Reviews and Ratings
  - Rolls SI33 Owners Manual and Bestseller Lists
5. Accessing Rolls SI33 Owners Manual Free and Paid eBooks

- Rolls SI33 Owners Manual Public Domain eBooks
  - Rolls SI33 Owners Manual eBook Subscription Services
  - Rolls SI33 Owners Manual Budget-Friendly Options
6. Navigating Rolls SI33 Owners Manual eBook Formats
- ePub, PDF, MOBI, and More
  - Rolls SI33 Owners Manual Compatibility with Devices
  - Rolls SI33 Owners Manual Enhanced eBook Features
7. Enhancing Your Reading Experience
- Adjustable Fonts and Text Sizes of Rolls SI33 Owners Manual
  - Highlighting and Note-Taking Rolls SI33 Owners Manual
  - Interactive Elements Rolls SI33 Owners Manual
8. Staying Engaged with Rolls SI33 Owners Manual
- Joining Online Reading Communities
  - Participating in Virtual Book Clubs
  - Following Authors and Publishers Rolls SI33 Owners Manual
9. Balancing eBooks and Physical Books Rolls SI33 Owners Manual
- Benefits of a Digital Library
  - Creating a Diverse Reading Collection Rolls SI33 Owners Manual
10. Overcoming Reading Challenges
- Dealing with Digital Eye Strain
  - Minimizing Distractions
  - Managing Screen Time
11. Cultivating a Reading Routine Rolls SI33 Owners Manual
- Setting Reading Goals Rolls SI33 Owners Manual
  - Carving Out Dedicated Reading Time
12. Sourcing Reliable Information of Rolls SI33 Owners Manual
- Fact-Checking eBook Content of Rolls SI33 Owners Manual
  - Distinguishing Credible Sources
13. Promoting Lifelong Learning
- Utilizing eBooks for Skill Development

- Exploring Educational eBooks
14. Embracing eBook Trends
- Integration of Multimedia Elements
  - Interactive and Gamified eBooks

### **Rolls SI33 Owners Manual Introduction**

In this digital age, the convenience of accessing information at our fingertips has become a necessity. Whether its research papers, eBooks, or user manuals, PDF files have become the preferred format for sharing and reading documents. However, the cost associated with purchasing PDF files can sometimes be a barrier for many individuals and organizations. Thankfully, there are numerous websites and platforms that allow users to download free PDF files legally. In this article, we will explore some of the best platforms to download free PDFs. One of the most popular platforms to download free PDF files is Project Gutenberg. This online library offers over 60,000 free eBooks that are in the public domain. From classic literature to historical documents, Project Gutenberg provides a wide range of PDF files that can be downloaded and enjoyed on various devices. The website is user-friendly and allows users to search for specific titles or browse through different categories. Another reliable platform for downloading Rolls SI33 Owners Manual free PDF files is Open Library. With its vast collection of over 1 million eBooks, Open Library has something for every reader. The website offers a seamless experience by providing options to borrow or download PDF files. Users simply need to create a free account to access this treasure trove of knowledge. Open Library also allows users to contribute by uploading and sharing their own PDF files, making it a collaborative platform for book enthusiasts. For those interested in academic resources, there are websites dedicated to providing free PDFs of research papers and scientific articles. One such website is Academia.edu, which allows researchers and scholars to share their work with a global audience. Users can download PDF files of research papers, theses, and dissertations covering a wide range of subjects. Academia.edu also provides a platform for discussions and networking within the academic community. When it comes to downloading Rolls SI33 Owners Manual free PDF files of magazines, brochures, and catalogs, Issuu is a popular choice. This digital publishing platform hosts a vast collection of publications from around the world. Users can search for specific titles or explore various categories and genres. Issuu offers a seamless reading experience with its user-friendly interface and allows users to download PDF files for offline reading. Apart from dedicated platforms, search engines also play a crucial role in finding free PDF files. Google, for instance, has an advanced search feature that allows users to filter results by file type. By specifying the file type as "PDF," users can find websites that offer free PDF downloads on a specific topic. While downloading Rolls SI33 Owners Manual free PDF files is convenient, its important to note that copyright laws must be respected. Always ensure that the PDF files you download are legally available

for free. Many authors and publishers voluntarily provide free PDF versions of their work, but its essential to be cautious and verify the authenticity of the source before downloading Rolls SI33 Owners Manual. In conclusion, the internet offers numerous platforms and websites that allow users to download free PDF files legally. Whether its classic literature, research papers, or magazines, there is something for everyone. The platforms mentioned in this article, such as Project Gutenberg, Open Library, Academia.edu, and Issuu, provide access to a vast collection of PDF files. However, users should always be cautious and verify the legality of the source before downloading Rolls SI33 Owners Manual any PDF files. With these platforms, the world of PDF downloads is just a click away.

### **FAQs About Rolls SI33 Owners Manual Books**

How do I know which eBook platform is the best for me? Finding the best eBook platform depends on your reading preferences and device compatibility. Research different platforms, read user reviews, and explore their features before making a choice. Are free eBooks of good quality? Yes, many reputable platforms offer high-quality free eBooks, including classics and public domain works. However, make sure to verify the source to ensure the eBook credibility. Can I read eBooks without an eReader? Absolutely! Most eBook platforms offer webbased readers or mobile apps that allow you to read eBooks on your computer, tablet, or smartphone. How do I avoid digital eye strain while reading eBooks? To prevent digital eye strain, take regular breaks, adjust the font size and background color, and ensure proper lighting while reading eBooks. What the advantage of interactive eBooks? Interactive eBooks incorporate multimedia elements, quizzes, and activities, enhancing the reader engagement and providing a more immersive learning experience. Rolls SI33 Owners Manual is one of the best book in our library for free trial. We provide copy of Rolls SI33 Owners Manual in digital format, so the resources that you find are reliable. There are also many Ebooks of related with Rolls SI33 Owners Manual. Where to download Rolls SI33 Owners Manual online for free? Are you looking for Rolls SI33 Owners Manual PDF? This is definitely going to save you time and cash in something you should think about. If you trying to find then search around for online. Without a doubt there are numerous these available and many of them have the freedom. However without doubt you receive whatever you purchase. An alternate way to get ideas is always to check another Rolls SI33 Owners Manual. This method for see exactly what may be included and adopt these ideas to your book. This site will almost certainly help you save time and effort, money and stress. If you are looking for free books then you really should consider finding to assist you try this. Several of Rolls SI33 Owners Manual are for sale to free while some are payable. If you arent sure if the books you would like to download works with for usage along with your computer, it is possible to download free trials. The free guides make it easy for someone to free access online library for download books to your device. You can get free download on free trial for lots of books

categories. Our library is the biggest of these that have literally hundreds of thousands of different products categories represented. You will also see that there are specific sites catered to different product types or categories, brands or niches related with Rolls Sl33 Owners Manual. So depending on what exactly you are searching, you will be able to choose e books to suit your own need. Need to access completely for Campbell Biology Seventh Edition book? Access Ebook without any digging. And by having access to our ebook online or by storing it on your computer, you have convenient answers with Rolls Sl33 Owners Manual To get started finding Rolls Sl33 Owners Manual, you are right to find our website which has a comprehensive collection of books online. Our library is the biggest of these that have literally hundreds of thousands of different products represented. You will also see that there are specific sites catered to different categories or niches related with Rolls Sl33 Owners Manual So depending on what exactly you are searching, you will be able to choose ebook to suit your own need. Thank you for reading Rolls Sl33 Owners Manual. Maybe you have knowledge that, people have search numerous times for their favorite readings like this Rolls Sl33 Owners Manual, but end up in harmful downloads. Rather than reading a good book with a cup of coffee in the afternoon, instead they juggled with some harmful bugs inside their laptop. Rolls Sl33 Owners Manual is available in our book collection an online access to it is set as public so you can download it instantly. Our digital library spans in multiple locations, allowing you to get the most less latency time to download any of our books like this one. Merely said, Rolls Sl33 Owners Manual is universally compatible with any devices to read.

### **Find Rolls Sl33 Owners Manual :**

[sepedi home laguage june exam pmemo grade11](#)

[service 4 wheel drive light hummer h3](#)

### **sequencing the 3 bears**

[sepedi p1 grade11question papers of polokwane](#)

[service centre samsung indonesia](#)

[service audi a6 4f kosten](#)

### **sepedi paper grade 1memorandum**

[sepedi paper 1 2015 memo](#)

[sentry key theft deterrent system problems](#)

[separation of a mixture using chromatography answers](#)

[series 40 m46 variable pumps service manual](#)

### **series 63 test questions**

[september intake of machakos](#)



**semester two final study guide chemistry**  
sequences and series problems precalculus key

**Rolls SI33 Owners Manual :**

*singapore basic cardiac life support and automated external* - Jun 07 2022

web abstract basic cardiac life support and automated external defibrillation bcls aed refers to the skills required in resuscitating cardiac arrest casualties on recognising cardiac arrest the rescuer should call for 995 for emergency ambulance and immediately initiate chest compressions good quality chest compressions are performed

231 leaders graduate from the goh keng swee command and - Apr 17 2023

web oct 18 2022 minister for defence dr ng eng hen officiated at the goh keng swee command and staff college gks csc command and staff course csc 2022 graduation ceremony held at the istana this evening this ceremony marked the completion of the 53rd csc 23rd csc national service and the 18th and 19th csc

clefs concours kha gnes litta c rature 2022 old joniandfriends - Jul 08 2022

web 2 clefs concours kha gnes litta c rature 2022 07 28 version which supersedes the original published text three convicts share a cramped prison cell there is no question as to which of them is the dominant dog in the pack green eyes yeux verts has brutally murdered a woman and is to be executed lefranc and the younger novice

pdf clefs concours kha gnes litta c rature - Dec 13 2022

web clefs concours kha gnes litta c rature biographie universelle ancienne et moderne supplément ou suite de l histoire par ordre alphabétique de la vie publique et privée de tous les hommes qui se sont fait remarquer par leurs écrits leurs actions leurs talents leurs vertus ou leurs crimes ouvrage entièrement neuf

*read free dictionnaire de litta c ratures de langue arabe e* - May 06 2022

web jul 15 2023 travers la litta c rature classic reprint propos de notre litta c rature nationale classic reprint l espagne la litta c rature franaaise contemporaine 1827 1849 tableau de la litta c rature franaaise au xvie siacle la hongrie romania 1921 vip popcorn melody villa kérylos essai d une bibliographie de la litta c rature frisonne

clefs concours kha gnes litta c rature - May 18 2023

web the course of guides you could enjoy now is clefs concours kha gnes litta c rature below three sisters investigate jiro akagawa 1989 atlas of the vascular plants of texas ferns gymnosperms monocots billie lee turner 2003 boswelliana james boswell 2021 12 16 the book boswelliana the commonplace book of james boswell with a

**read free clefs concours kha gnes litta c rature** - Feb 15 2023

web clefs concours kha gnes litta c rature empire of silver conqueror book 4 oct 30 2021 the 4th novel in the bestselling

conqueror series continuing the life and adventures of the mighty khan dynasty

*clefs concours kha gnes litta c rature ssl krop* - Sep 22 2023

web clefs concours kha gnes litta c rature download you can access a selection of dramatic publications in the thriller style whether you prefer mental thrillers or action packed suspense you make sure to find clefs concours kha gnes litta c rature book that will keep you on the edge of your seat love

*downloadable free pdfs clefs concours kha gnes litta c rature* - Oct 23 2023

web clefs concours kha gnes litta c rature la litta c rature franaaise contemporaine 1827 1849 apr 26 2023 le correspondant 1904 aug 26 2020 tableau de la litta c rature franaaise au xvie siacle mar 26 2023 mon ciel et ma terre jan 29 2021 roman témoignage roman psychologique intime

**clefs concours kha gnes litta c rature pdf pdf** - Sep 10 2022

web jun 29 2023 clefs concours kha gnes litta c rature pdf if you ally dependence such a referred clefs concours kha gnes litta c rature pdf book that will have the funds for you worth get the completely best seller from us currently from several preferred authors if you desire to funny books lots of novels tale jokes and more fictions collections are

**Ita joint news release by the land transport authority Ita** - Mar 04 2022

web nov 15 2022 the most pollutive vehicles in band c will still incur the highest total cost of ownership after applying the cves surcharge details of the adjustments to the incentives for the adjusted cves are in annex b the comparison of the total cost of ownership between band a b and c lcvs is shown in annex c adjustments to early turnover

**clefs concours kha gnes litta c rature pdf** - Jan 14 2023

web apr 29 2023 clefs concours kha gnes litta c rature pdf is available in our digital library an online access to it is set as public so you can download it instantly our digital library spans in multiple countries allowing you to

*clefs concours kha gnes litta c rature pdf james aliferis pdf* - Jun 19 2023

web clefs concours kha gnes litta c rature pdf when somebody should go to the books stores search opening by shop shelf by shelf it is in point of fact problematic this is why we offer the books compilations in this website it will utterly ease you to see guide clefs concours kha gnes litta c rature pdf as you such as

**singapore trainees careers k l gates** - Apr 05 2022

web we are accepting applications for training contracts as well as for attachments and internships if interested please send a cover letter curriculum vitae and transcripts a level ib results or equivalent and llb examination results to k l gates straits law llc 9 raffles place 32 00 republic plaza singapore 048619

**clefs concours kha gnes litta c rature wef tamu** - Oct 11 2022

web recognizing the quirk ways to acquire this book clefs concours kha gnes litta c rature is additionally useful you have

remained in right site to start getting this info acquire the clefs concours kha gnes litta c rature link that we give here and check out the link you could purchase guide clefs concours kha gnes litta c rature or get it as

**justice et litta c rature download only** - Aug 09 2022

web the best website to see the unbelievable book to have clefs concours kha gnes litta c rature downloaded from lsamp coas howard edu by guest howard yadira xviii sia cle litta c rature textes et documents pdf jul 13 2022

**clefs concours kha gnes litta c rature download only** - Aug 21 2023

web 2 clefs concours kha gnes litta c rature 2023 01 03 with a way of life in the fast lane the sweaty bodies at studio 54 the lines of cocaine the indescribable feeling that you could always be at the top of your game and never come down but down she came after her early stardom and problems followed in the wake including the death of her

*clefs concours kha gnes litta c rature james aliferis pdf* - Jul 20 2023

web clefs concours kha gnes litta c rature is available in our digital library an online access to it is set as public so you can download it instantly our books collection spans in multiple countries allowing you to get the most less latency time to

**clefs concours kha gnes litta c rature pdf portal nivbook co** - Nov 12 2022

web related with clefs concours kha gnes litta c rature 110 plug wiring diagram 10578 science center drive 14100 nw science park drive portland or 97229

**singapore gardeners cup 2022 results national parks board** - Mar 16 2023

web 2 singapore gardeners cup 2022 results s n awards plot theme implementing partner sgc3 best of show gold north east district garden of nectar hua hng trading co pte

**lora leigh s breeds books in order fantastic fiction** - Jun 13 2023

web breeds 1 tempting the beast 2003 2 the man within 2005 3 elizabeth s wolf 2005 4 kiss of heat 2005 5 soul deep 2004 6 the breed next door 2005 7 megan s mark 2006 8 harmony s way 2006

*the breeds novels 1 6 breeds 6 8 11 13 by lora leigh goodreads* - Mar 10 2023

web 4 53 591 ratings 12 reviews animal hungers and human emotions entwine like strands of dna in these six novels in the sexy paranormal series featuring the genetically engineered breeds and those who created them from the 1 new york times bestselling author of lawe s justice and deadly sins megan s mark

**breeds series by lora leigh goodreads** - Jul 14 2023

web breeds series 23 primary works 45 total works book 1 tempting the beast by lora leigh 3 91 23 683 ratings 1 243 reviews published 2003 19 editions callan lyons is a genetic experiment one of six f want to read rate it book 2 the man within by lora leigh 4 05 12 979 ratings 510 reviews published 2004 16 editions

**amazon com lora leigh breeds series** - Dec 07 2022

web amazon com lora leigh breeds series 1 48 of over 1 000 results for lora leigh breeds series results tempting the beast breeds book 1 book 1 of 28 a novel of the breeds 2 515 kindle 449 digital list price 5 99 available instantly other formats audible audiobook paperback elizabeth s wolf a novel of the breeds book 3

**rule breaker breeds series 29 by lora leigh paperback** - Mar 30 2022

web nov 4 2014 there s a fine line between animal instinct and human desire and in the newest book in her highly erotic saga fresh fiction of the breeds lora leigh crosses it lion breed and enforcer rule breaker has a few rules he doesn t break [lora leigh books in order 113 book series most](#) - Feb 26 2022

web lora leigh is a best selling author known for her romantic and erotic novels she has written numerous series including the breed nauti and elite ops series if you re reading her books in order you might want to start with tempting the beast which is the first book in the breed series

**elizabeth s wolf the novel of the breeds series amazon com** - Apr 30 2022

web may 23 2018 it s elizabeth s wolf as you ve never seen it before new york times bestselling author lora leigh revisits one of her earliest breeds novels in this revised and expanded edition she brought him back from death and made him live again [breed chronological order author lora leigh](#) - Aug 15 2023

web the breed character is listed first 1 tempting the beast callan and merinus lion breed merinus tyler discovers a secret in the kentucky mountains men and women who were created in and escaped from the labs of their creators human with the genetics of the predators of the world

*read breeds series by lora leigh online for free allfreenovel* - Jan 28 2022

web breeds novels find something to read cross breed breeds 23 by lora leigh paranormal wake a sleeping tiger breeds 22 by lora leigh paranormal bengal s quest breeds 21 by lora leigh paranormal rule breaker breeds 20 by lora leigh [order of lora leigh books orderofbooks com](#) - Jun 01 2022

web lora leigh is an american novelist of erotic romance and fantasy she is best known for her series the breeds one of her novels deadly sins was referred to as a fun guilty pleasure in a review by the international business times news lora organizes an annual reader s appreciation weekend so she can connect with her fans and discuss her work

**lora leigh breed series reading order maryse s book blog** - Feb 09 2023

web jun 18 2009 i absolutely became obsessed with lora leigh s breeds series i stumbled upon tempting the beast and went crazy over the series it id a great and plot the series continues to intrigue and posses fascination along with curiosity plus the romance is beautifully written and the sex scenes are something to get a few blushes over

**upcoming releases author lora leigh** - Dec 27 2021

web coming soon releases february 6 2024 releases tba releases march 26 2024

**author lora leigh** - Aug 03 2022

web what readers are saying lora leigh doesn't disappoint when it comes to sexiness intrigue and an added little bit of humor lora leigh doesn't disappoint when it comes to sexiness intrigue and an added little bit of humor another powerful and highly erotic saga of the breeds highly charged and carnal

**all book series by lora leigh goodreads** - Oct 05 2022

web lora leigh has 243 books on goodreads with 1009865 ratings lora leigh's most popular series is nauti

**amazon ca lora leigh breeds series** - Jul 02 2022

web by lora leigh 4.5 out of 5 stars 4.5 208 kindle edition 9.99 9.99 22.00 22.00 available instantly other formats paperback audio cd cross breed by lora leigh 4.7 out of 5 stars 4.7 1.055 mass market paperback 10.88 10.88 free delivery thu dec 15 on your first order arrives before christmas only 7 left in stock more on the way

**breeds series by lora leigh books goodreads** - Jan 08 2023

web books shelved as breeds series by lora leigh too hot to touch by lora leigh the breeds novels 1-6 by lora leigh navarro's promise styx's storm benga

*breeds series in order by lora leigh fictiondb* - May 12 2023

web series list breeds 32 books by lora leigh a sortable list in reading order and chronological order with publication date genre and rating

**cross breed a novel of the breeds book 32 kindle edition by leigh** - Sep 04 2022

web sep 25 2018 lora leigh is a 1 new york times bestselling romance author known for the breeds series and the nauti boys series most days she can be found in front of her computer weaving daydreams while sipping the ambrosia of the gods also known as coffee

*lora leigh wikipedia* - Nov 06 2022

web lora leigh born march 6 1965 is a new york times bestselling author of erotic romance novels leigh started publishing with electronic publisher ellora's cave in 2003 leigh's longest running series is the breeds she won the 2009 rt award for erotica leigh was born in ohio and raised in martin county kentucky us

*a novel of the breeds 28 book series kindle edition* - Apr 11 2023

web from new york times bestselling author lora leigh comes a new revised edition of a beloved classic in the passionate breed series elizabeth's wolf won the hearts of readers everywhere when it was first released and now experience the magic again in this special expanded edition

[in un batter d'occhi una prospettiva sul montaggi pdf](#) - Jan 27 2022

web jul 16 2023 ma le indagini di tom lo porteranno su una pista ancora più pericolosa dietro l'atroce massacro c'è un

complotto per rovesciare il regime demarchico ordito da una  
in un batter d occhi una prospettiva sul montaggio - Nov 05 2022

web scaricare libri in un batter d occhi una prospettiva sul in un batter d occhi una nuova prospettiva empirica sull neural  
mechanisms genoa turin seminars 2017 edition in un

in un batter d occhi una prospettiva sul montaggio - Jul 01 2022

web walter murch in un batter d occhi una prospettiva sul montaggio cinematografico nell era digitale walter murch vincitore  
di un doppio oscar caso unico nella storia

in un batter d occhi una prospettiva sul montaggio - May 11 2023

web dal montaggio tradizionale a quello digitale nella nuova edizione di questo libro murch ne narra i pro e i contro partendo  
dalla sua lunga esperienza e lasciandosi andare a

**in un batter d occhi una prospettiva sul montaggio** - Apr 29 2022

web in un batter d occhi una prospettiva sul montaggio cinematografico nell era digitale il grande cinema murch walter  
fumagalli gianluca amazon es libros

**in un batter d occhi una prospettiva sul montaggio** - Mar 29 2022

web occhi una prospettiva sul in un batter d occhi una prospettiva sul montaggio in un batter d occhi una nuova prospettiva  
empirica sull walter murch in un batter d occhi

**in un batter d occhi una prospettiva sul montaggio** - Apr 10 2023

web in un batter d occhi una prospettiva sul montaggio cinematografico nell era digitale è un libro di walter murch  
pubblicato da lindau nella collana il grande cinema acquista su

in un batter d occhi walter murch in un batter - May 31 2022

web in un batter d occhi una prospettiva sul montaggio cinematografico nell era digitale murch walter fumagalli gianluca  
amazon fr livres

in un batter d occhi una prospettiva sul montaggio - Nov 24 2021

web prospettiva sul montaggio in un batter d occhi una prospettiva sul montaggio facoltà di lettere e filosofia il futuro è  
passato qui in un batter d occhi una prospettiva sul

*in un batter d occhi una prospettiva sul montaggio* - Jan 07 2023

web in un batter d occhi una prospettiva sul montaggio cinematografico nell era digitale cercando di svelare un mistero  
basilare del cinema perché funzionano gli stacchi

**in un batter d occhi una prospettiva sul montaggio** - Oct 24 2021

**in un batter d occhi una prospettiva sul montaggio** - Feb 25 2022

web in un batter d occhi una prospettiva sul montaggio cinematografico nell era digitale a new pocket dictionary of the italian and english languages from baretti bottarelli

*in un batter d occhi una prospettiva sul montaggio hoepli* - Aug 02 2022

web in un batter d occhi una prospettiva sul montaggio cinematografico nell era digitale purch walter fumagalli gianluca on amazon com au free shipping on eligible

in un batter d occhi una prospettiva sul montaggio - Dec 06 2022

web in un batter d occhi una prospettiva sul montaggio cinematografico nell era digitale walter purch 9788871806525 books amazon ca

*in un batter d occhi una prospettiva sul montaggio* - Sep 03 2022

web in un batter d occhi una prospettiva sul montaggio cinematografico è un libro di purch walter edito da lindau a gennaio 2007 ean 9788871806525 puoi acquistarlo sul sito

**in un batter d occhi una prospettiva sul montaggio** - Feb 08 2023

web in un batter d occhi una prospettiva sul montaggio cinematografico nell era digitale è un libro di walter purch pubblicato da lindau nella collana il grande cinema acquista su

*in un batter d occhi una prospettiva sul montaggio* - Mar 09 2023

web la seconda sezione del libro dedicata al montaggio digitale inedita e scritta da purch appositamente per l edizione italiana analizza in profondità i pro e i contro del montaggio

**in un batter d occhi una prospettiva sul montaggio pdf** - Dec 26 2021

web in un batter d occhi una prospettiva sul montaggio may 10th 2020 in un batter d occhi una prospettiva sul montaggio cinematografico nell era digitale è un libro di purch

**in un batter d occhi una prospettiva sul montaggio** - Oct 04 2022

web in un batter d occhi una prospettiva sul montaggio cinematografico nell era digitale on amazon com free shipping on qualifying offers una prospettiva sul montaggio

*in un batter d occhi una prospettiva sul montaggio* - Jul 13 2023

web una prospettiva sul montaggio cinematografico nell era digitale è un libro di walter purch pubblicato da lindau nella collana saggi acquista su ibs a 17 10 una prospettiva sul

*in un batter d occhi una prospettiva sul montaggio* - Aug 14 2023

web in un batter d occhi una prospettiva sul montaggio cinematografico nell era digitale purch walter fumagalli gianluca amazon it libri

**in un batter d occhi una prospettiva sul montaggio** - Jun 12 2023

web in un batter d occhi una prospettiva sul montaggio may 15th 2020 in un batter d occhi una prospettiva sul montaggio  
cinematografico nell era digitale è un libro di walter