

1. SPECIFICATIONS

Item	MODEL	50	50S
Overall Length,	mm	700	
Overall Width,	mm	310	
Overall Height, S-L+U	mm	1017 • 1144 • 1271	978 • 1005 • 1232
Trimmed Height, S-L+U	mm	435 • 562 • 689	
Weight, S-L+U	Kg	20 • 20.5 • 21	19 • 19.5 • 20
Output,	kW	3.7	
Max. Operating Range,	rpm	4,500 - 5,500	
Engine Type		2-Stroke Cycle	
Number of Cylinders		1	
Bore and Stroke,	mm	55 × 43	
Piston Displacement,	mL	162	
Exhaust System		through hub exhaust	
Cooling System		forced water cooling	
Engine Lubrication		engine oil mixed gasoline	
Starting System		manual starter	
Ignition System		Flywheel Magneto C.D. Ignition	
Spark Plug		NGK BPR7HS10	
Trim Stages		6 Position	
Fuel/Oil Mixing Ratio		Unleaded gasoline 50: Genuine 2-stroke engine oil 1	
Gear Oil		Genuine Gear Oil API GL5, SAE #80-90, Approx. 195mL.	
Fuel Tank Capacity,	L	2.5	12
Gear Reduction Ratio		13 : 28	

2. NAME OF PARTS

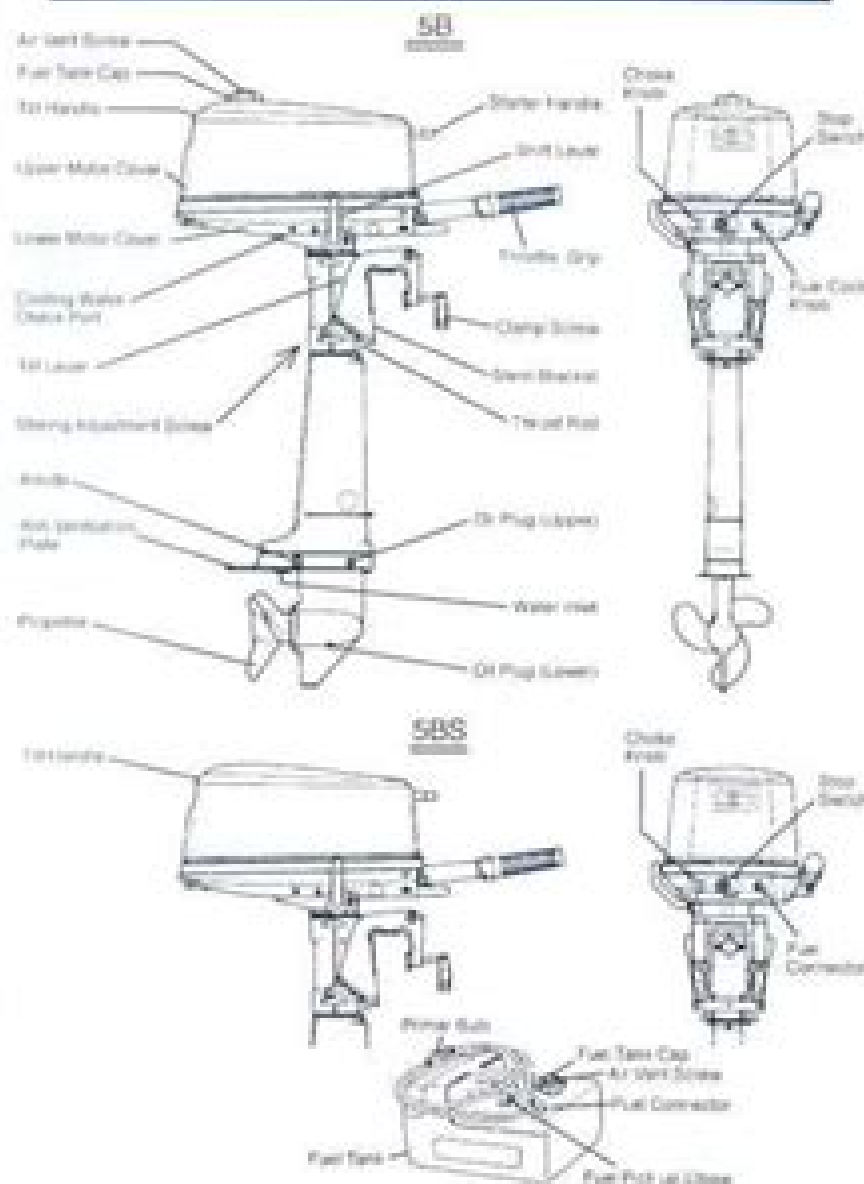

Owners Manual Parsun 5hp

**Nash-Kelvinator Corporation. Nash
Motors Division**



Owners Manual Parsun 5hp:

The book delves into Owners Manual Parsun 5hp. Owners Manual Parsun 5hp is a crucial topic that needs to be grasped by everyone, ranging from students and scholars to the general public. The book will furnish comprehensive and in-depth insights into Owners Manual Parsun 5hp, encompassing both the fundamentals and more intricate discussions.

1. The book is structured into several chapters, namely:
 - Chapter 1: Introduction to Owners Manual Parsun 5hp
 - Chapter 2: Essential Elements of Owners Manual Parsun 5hp
 - Chapter 3: Owners Manual Parsun 5hp in Everyday Life
 - Chapter 4: Owners Manual Parsun 5hp in Specific Contexts
 - Chapter 5: Conclusion
2. In chapter 1, this book will provide an overview of Owners Manual Parsun 5hp. This chapter will explore what Owners Manual Parsun 5hp is, why Owners Manual Parsun 5hp is vital, and how to effectively learn about Owners Manual Parsun 5hp.
3. In chapter 2, the author will delve into the foundational concepts of Owners Manual Parsun 5hp. This chapter will elucidate the essential principles that need to be understood to grasp Owners Manual Parsun 5hp in its entirety.
4. In chapter 3, the author will examine the practical applications of Owners Manual Parsun 5hp in daily life. This chapter will showcase real-world examples of how Owners Manual Parsun 5hp can be effectively utilized in everyday scenarios.
5. In chapter 4, the author will scrutinize the relevance of Owners Manual Parsun 5hp in specific contexts. This chapter will explore how Owners Manual Parsun 5hp is applied in specialized fields, such as education, business, and technology.
6. In chapter 5, this book will draw a conclusion about Owners Manual Parsun 5hp. The final chapter will summarize the key points that have been discussed throughout the book.

This book is crafted in an easy-to-understand language and is complemented by engaging illustrations. It is highly recommended for anyone seeking to gain a comprehensive understanding of Owners Manual Parsun 5hp.

https://crm.avenza.com/public/scholarship/Download_PDFS/santo_antao_guide_book.pdf

Table of Contents Owners Manual Parsun 5hp

1. Understanding the eBook Owners Manual Parsun 5hp
 - The Rise of Digital Reading Owners Manual Parsun 5hp
 - Advantages of eBooks Over Traditional Books
2. Identifying Owners Manual Parsun 5hp
 - Exploring Different Genres
 - Considering Fiction vs. Non-Fiction
 - Determining Your Reading Goals
3. Choosing the Right eBook Platform
 - Popular eBook Platforms
 - Features to Look for in an Owners Manual Parsun 5hp
 - User-Friendly Interface
4. Exploring eBook Recommendations from Owners Manual Parsun 5hp
 - Personalized Recommendations
 - Owners Manual Parsun 5hp User Reviews and Ratings
 - Owners Manual Parsun 5hp and Bestseller Lists
5. Accessing Owners Manual Parsun 5hp Free and Paid eBooks
 - Owners Manual Parsun 5hp Public Domain eBooks
 - Owners Manual Parsun 5hp eBook Subscription Services
 - Owners Manual Parsun 5hp Budget-Friendly Options
6. Navigating Owners Manual Parsun 5hp eBook Formats
 - ePub, PDF, MOBI, and More
 - Owners Manual Parsun 5hp Compatibility with Devices
 - Owners Manual Parsun 5hp Enhanced eBook Features
7. Enhancing Your Reading Experience
 - Adjustable Fonts and Text Sizes of Owners Manual Parsun 5hp
 - Highlighting and Note-Taking Owners Manual Parsun 5hp
 - Interactive Elements Owners Manual Parsun 5hp
8. Staying Engaged with Owners Manual Parsun 5hp

- Joining Online Reading Communities
 - Participating in Virtual Book Clubs
 - Following Authors and Publishers Owners Manual Parsun 5hp
9. Balancing eBooks and Physical Books Owners Manual Parsun 5hp
- Benefits of a Digital Library
 - Creating a Diverse Reading Collection Owners Manual Parsun 5hp
10. Overcoming Reading Challenges
- Dealing with Digital Eye Strain
 - Minimizing Distractions
 - Managing Screen Time
11. Cultivating a Reading Routine Owners Manual Parsun 5hp
- Setting Reading Goals Owners Manual Parsun 5hp
 - Carving Out Dedicated Reading Time
12. Sourcing Reliable Information of Owners Manual Parsun 5hp
- Fact-Checking eBook Content of Owners Manual Parsun 5hp
 - Distinguishing Credible Sources
13. Promoting Lifelong Learning
- Utilizing eBooks for Skill Development
 - Exploring Educational eBooks
14. Embracing eBook Trends
- Integration of Multimedia Elements
 - Interactive and Gamified eBooks

Owners Manual Parsun 5hp Introduction

In today's digital age, the availability of Owners Manual Parsun 5hp books and manuals for download has revolutionized the way we access information. Gone are the days of physically flipping through pages and carrying heavy textbooks or manuals. With just a few clicks, we can now access a wealth of knowledge from the comfort of our own homes or on the go. This article will explore the advantages of Owners Manual Parsun 5hp books and manuals for download, along with some popular platforms that offer these resources. One of the significant advantages of Owners Manual Parsun 5hp books and manuals for download is the cost-saving aspect. Traditional books and manuals can be costly, especially if you need to purchase several of

them for educational or professional purposes. By accessing Owners Manual Parsun 5hp versions, you eliminate the need to spend money on physical copies. This not only saves you money but also reduces the environmental impact associated with book production and transportation. Furthermore, Owners Manual Parsun 5hp books and manuals for download are incredibly convenient. With just a computer or smartphone and an internet connection, you can access a vast library of resources on any subject imaginable. Whether you're a student looking for textbooks, a professional seeking industry-specific manuals, or someone interested in self-improvement, these digital resources provide an efficient and accessible means of acquiring knowledge. Moreover, PDF books and manuals offer a range of benefits compared to other digital formats. PDF files are designed to retain their formatting regardless of the device used to open them. This ensures that the content appears exactly as intended by the author, with no loss of formatting or missing graphics. Additionally, PDF files can be easily annotated, bookmarked, and searched for specific terms, making them highly practical for studying or referencing. When it comes to accessing Owners Manual Parsun 5hp books and manuals, several platforms offer an extensive collection of resources. One such platform is Project Gutenberg, a nonprofit organization that provides over 60,000 free eBooks. These books are primarily in the public domain, meaning they can be freely distributed and downloaded. Project Gutenberg offers a wide range of classic literature, making it an excellent resource for literature enthusiasts. Another popular platform for Owners Manual Parsun 5hp books and manuals is Open Library. Open Library is an initiative of the Internet Archive, a nonprofit organization dedicated to digitizing cultural artifacts and making them accessible to the public. Open Library hosts millions of books, including both public domain works and contemporary titles. It also allows users to borrow digital copies of certain books for a limited period, similar to a library lending system. Additionally, many universities and educational institutions have their own digital libraries that provide free access to PDF books and manuals. These libraries often offer academic texts, research papers, and technical manuals, making them invaluable resources for students and researchers. Some notable examples include MIT OpenCourseWare, which offers free access to course materials from the Massachusetts Institute of Technology, and the Digital Public Library of America, which provides a vast collection of digitized books and historical documents. In conclusion, Owners Manual Parsun 5hp books and manuals for download have transformed the way we access information. They provide a cost-effective and convenient means of acquiring knowledge, offering the ability to access a vast library of resources at our fingertips. With platforms like Project Gutenberg, Open Library, and various digital libraries offered by educational institutions, we have access to an ever-expanding collection of books and manuals. Whether for educational, professional, or personal purposes, these digital resources serve as valuable tools for continuous learning and self-improvement. So why not take advantage of the vast world of Owners Manual Parsun 5hp books and manuals for download and embark on your journey of knowledge?

FAQs About Owners Manual Parsun 5hp Books

How do I know which eBook platform is the best for me? Finding the best eBook platform depends on your reading preferences and device compatibility. Research different platforms, read user reviews, and explore their features before making a choice. Are free eBooks of good quality? Yes, many reputable platforms offer high-quality free eBooks, including classics and public domain works. However, make sure to verify the source to ensure the eBook credibility. Can I read eBooks without an eReader? Absolutely! Most eBook platforms offer web-based readers or mobile apps that allow you to read eBooks on your computer, tablet, or smartphone. How do I avoid digital eye strain while reading eBooks? To prevent digital eye strain, take regular breaks, adjust the font size and background color, and ensure proper lighting while reading eBooks. What the advantage of interactive eBooks? Interactive eBooks incorporate multimedia elements, quizzes, and activities, enhancing the reader engagement and providing a more immersive learning experience. Owners Manual Parsun 5hp is one of the best book in our library for free trial. We provide copy of Owners Manual Parsun 5hp in digital format, so the resources that you find are reliable. There are also many Ebooks of related with Owners Manual Parsun 5hp. Where to download Owners Manual Parsun 5hp online for free? Are you looking for Owners Manual Parsun 5hp PDF? This is definitely going to save you time and cash in something you should think about.

Find Owners Manual Parsun 5hp :

santo antao guide book

samsung sp h710ae projectors owners manual

sanctuary buried witsec town series book 2

~~sankyo es 66xl super 8 movie camera manual~~

sanctuaire la trilogie du roi sauvage t

~~samsung zeal user manual~~

~~san ramon california travel guide~~

samsung washing machine instructions

samsung tv guide on screen

~~san diego pep skin report~~

sanco sewing machine guide

sansa usb user guide

samsung un55es6580 tvs owners manual

samsung v hd box manual
[sanyo drw 5instruction manual](#)

Owners Manual Parsun 5hp :

free download adobe reader for nokia 5230 - Aug 21 2023

web you can use it on s60 5th devices like nokia 5230 or nokia 5800 you can view any pdf on it but if your pdf file is too large the ram of the device will not be able to handle it so for ram limitations do not try to open 250 or 300 mb

free mobile pdf reader for nokia 5230 by seanpodvs issuu - Dec 13 2022

web sep 4 2017 read free mobile pdf reader for nokia 5230 by seanpodvs on issuu and browse thousands of other publications on our platform start here

download adobe reader for windows 10 best software apps softonic - Mar 04 2022

web download adobe reader for windows 10 free and safe download download the latest version of the top software games programs and apps in 2023

adobe reader nokia 5230 download free download fyxm net - Feb 15 2023

web free secure download download free adobe reader nokia 5230 download here now click to download adobe reader nokia 5230 download for free now

[adobe reader download](#) - Apr 05 2022

web sep 23 2023 a streamlined and light version of adobe reader dc adobe acrobat reader lite is a free software used for viewing printing and annotating pdf files developed by adobe adobe reader lite is a stripped version of the popular adobe reader dc document cloud bringing you all the essential tools to interact with pdfs but without

[adobe reader for nokia 5230 pdf uniport edu](#) - Aug 09 2022

web jul 15 2023 adobe reader for nokia 5230 1 9 downloaded from uniport edu ng on july 15 2023 by guest adobe reader for nokia 5230 this is likewise one of the factors by obtaining the soft documents of this adobe reader for nokia 5230 by online you might not require more period to spend to go to the book creation as capably as search for them

[adobe reader for nokia 5230 pdf copy china int indonesia travel](#) - May 06 2022

web introduction adobe reader for nokia 5230 pdf copy the care and feeding of ideas james l adams 1986 algorithms from and for nature and life berthold lausen 2013 08 28 this volume provides approaches and solutions to challenges occurring at the interface of research fields such as e g

[free download adobe reader nokia 5230 winsite](#) - Jun 19 2023

web adobe reader for symbian os software lets you to view adobe pdf files on nokia 6680 smartphones and nokia

communicator 9500 series and 9210 9290 devices you'll be able to download adobe pdf files to your symbian device a number of ways from the

nia 5230 5235 5800 x6 free apps store - Mar 16 2023

web apr 11 2011 new adobe reader le 2 5 for s60 3rd 5th edition mobile devices lets you view pdf adobe portable document format files on the go anytime anywhere enjoy enhanced pdf viewing with faster and easier to read single column text reflow that resizes documents for greatly improved readability on the small screen

pdf reader adobe acrobat reader - Sep 22 2023

web discover the best free pdf reader with adobe acrobat reader lets you read search print and interact with any type of pdf file

adobe reader for nokia 5230 store spiralny - Jun 07 2022

web 2 adobe reader for nokia 5230 2022 07 13 the book has 120 white pages with dot matrix that will help you while writing and sketching but at the same time gives you enough freedom for notes and other ideas it comes in handy format 6x9 inches equivalent to din a5 the nurse notebook is for those who have a fable for medicine or cure the nurse

adobe download adobe acrobat reader - Oct 23 2023

web download free adobe acrobat reader software for your windows mac os and android devices to view print and comment on pdf documents adobe acrobat reader the world's most trusted free pdf viewer

adobe reader for nokia 5230 software free download adobe - Oct 11 2022

web adobe reader for symbian os software lets you to view adobe pdf files on nokia 6680 smartphones and nokia communicator 9500 series and 9210 9290 devices you'll be able to download adobe pdf files to your symbian device a number of ways from the

adobe reader for nokia 5230 pdf uniport edu - Jul 08 2022

web jun 9 2023 epoch to download any of our books like this one merely said the adobe reader for nokia 5230 is universally compatible once any devices to read

adobe reader for nokia 5230 help environment harvard edu - Sep 10 2022

web 1 adobe reader for nokia 5230 recognizing the pretentiousness ways to acquire this ebook adobe reader for nokia 5230 is additionally useful you have remained in

adobe reader for nokia 5230 help environment harvard edu - Nov 12 2022

web adobe reader for nokia 5230 is available in our digital library an online access to it is set as public so you can download it instantly our book servers spans in multiple countries allowing you to get the most less latency time to download any of

pdf reader to be deployed to nokia 5230 phone acrobatusers com - Jul 20 2023

web feb 25 2011 we need to provision a pdf reader and ensure that it is properly licensed to the nokia 5230 phone we have an application that distributes content to a phone and one of our content types is pdf it is our understanding that the pdf reader requires a paid licence and we do not know how to download it install it and provision it with a licence

[adobe pdf reader nokia cnet download](#) - Apr 17 2023

web free to try paid adobe pdf reader nokia free download pdf reader for windows 7 pdf reader for windows 10 nitro pdf reader 64 bit and many more programs

adobe reader for 5530 nokia software winsite - Jan 14 2023

web ebook reader for nokia 9300 9500 is a viewer and organizer for electronic books ebook reader for the nokia 9300 9500 is a viewer and organizer for electronic books with ebook reader you can download and read ebooks from web based ebook stores

[adobe reader for nokia 5230 software winsite](#) - May 18 2023

web adobe reader for symbian os software lets you to view adobe pdf files on nokia 6680 smartphones and nokia communicator 9500 series and 9210 9290 devices youll be able to download adobe pdf files to your symbian device a number of ways from the

wiring diagram panel listrik ats amf pdf pdf e books scribd - Mar 13 2023

web wiring diagram panel listrik ats amf contains important information and a detailed explanation about wiring diagram panel listrik ats amf its contents of the package names of things and what they do setup and operation

pembuatan wiring diagram panel listrik teknisi listrik - Jul 17 2023

web wiring diagram merupakan gambar pengkabelan dalam instalasi listrik yang menggambarkan alamat posisi kabel simbol simbol kelistrikan seperti kontak saklar wiring diagram elektrik ini sangat diperlukan oleh panel maker dalam perencanaan pembuatan panel listrik panel kontrol

[panel distribusi listrik urutan dan jenis panel teknisi listrik](#) - Feb 12 2023

web may 6 2019 contoh wiring diagram simbol listrik standar internasional mesin industri simbol listrik wiring kontrol dan motor 3 phase rangkaian kontrol motor 3 phase panel distribusi listrik urutan dan jenis panel jasa instalasi listrik panel instrument inverter vsd plc hmi dan perbaikan mesin usaha industri karawang

cara mudah membuat wiring diagram panel listrik youtube - Jan 11 2023

web aug 5 2019 tutorial membuat wiring diagram load schedule panel listrik dengan autocad lengkap dengan bahannya langsung sedot paling bawah

electrical panel wiring diagram solisplc - Sep 07 2022

web electrical panel wiring diagrams are used to outline each device as well as the connection between the devices found

within an electrical panel as electrical panels are what will contain control systems panel wiring diagrams are commonly encountered by plc technicians and engineers although electrical panels may not be overly complex from

konsep 31 gambar diagram wiring panel listrik sdp blogger - Aug 06 2022

web jan 13 2021 poin pembahasan konsep 31 gambar diagram wiring panel listrik sdp adalah panel distribusi listrik lengkap wiring diagram panel distribusi diagram panel listrik gambar panel distribusi komponen panel listrik pdf panel sdp komponen panel listrik beserta fungsinya komponen panel sdp

belajar membaca wiring diagram kontrol listrik - Jan 31 2022

web jun 1 2022 video memberi penjelasan bagaimana membaca wiring diagram kontrol listrik dari nol video terbagi menjadi beberapa episode dan ini adalah episode yang pertama

5 software diagram listrik gratis terbaik brankaspedia - Jul 05 2022

web berikut adalah 5 software diagram kelistrikan gratis untuk windows software ini membantu agan merancang diagram rangkaian listrik dengan menambahkan berbagai perangkat dan instrumen listrik agan dapat menggunakan software ini untuk membuat desain listrik bangunan atau desain sirkuit listrik tertentu

gambar kerja wiring diagram instalasi listrik file dwg - May 03 2022

web fungsi dari wiring diagram instalasi listrik adalah untuk memetakan berbagai jenis beban pengaman grup panel mcb serta kwh meter yang di pasang dalam sebuah instalasi baik untuk rumah perusahaan sekolah pabrik dan lainnya wiring diagram menggambarkan cara pengawatan yang menghubungkan antara komponen dengan komponen lainnya

rangkaian dasar listrik pada gambar dan panel control - Nov 09 2022

web 1 rangkaian on rangkaian on pb on pada umumnya berwarna hijau dengan kontak no normally open pb on dalam kondisi normal kontak terbuka sehingga lampu tidak menyala jika pb on di tekan kontak akan tertutup dan arus listrik akan mengalir sehingga lampu menyala

5 rekomendasi software wiring diagram listrik terbaik - Jun 16 2023

web mar 25 2022 rekomendasi pertama dari software wiring diagram listrik adalah fritzing perangkat lunak ini dapat digunakan di pc dengan sistem operasi windows keunggulan dari aplikasi ini adalah menawarkan banyak rangkaian perangkat listrik serta instrumennya yang bervariasi dan menarik

tips membaca wiring diagram selamat datang di blog anton - Oct 08 2022

web jul 14 2021 tips membaca wiring diagram wiring diagram dalam dunia teknik sering kita temui gambar gambar yang berisi simbol simbol garis garis kode kode tertentu misalnya dalam wiring diagram sebuah panel listrik wiring diagram instalasi gedung dan lain lainnya

macam macam diagram instalasi listrik teknisi listrik - Dec 10 2022

web macam macam diagram instalasi listrik oleh teknik listrik juni 23 2022 contoh wiring diagram tidak sedikit yang menggunakan jasa pembuatan wiring diagram instalasi listrik kami tanpa memberikan contoh gambar diagram instalasi listrik

tips untuk membuat wiring diagram dari panel atau instalasi listrik - Apr 14 2023

web berikut tips untuk membuat wiring diagram dari panel atau instalasi listrik panel listrik kenali simbol masing masing komponen dalam panel gambar terlebih dahulu jalur power tegangan pada panel kemudian gambar jalur sistem kontrolnya jika ada instalasi listrik kenali simbol masing masing komponen dalam instalasi

pembahasan lengkap wiring diagram engineering - Aug 18 2023

web jul 24 2021 wiring diagram adalah suatu skema yang menjelaskan tentang hubungan antara satu komponen dengan komponen lainnya secara detail jadi diagram ini akan menghubungkan semua komponen pada rangkaian instalasi listrik tertentu

how to follow an electrical panel wiring diagram realpars - Mar 01 2022

web dec 2 2019 wire tag in the back of the emergency stop push button you see that we have four wires just as what we have on the wiring diagram two wires are tagged as 1 and two wires are tagged as 2 based on the diagram one of these wires with the tag 2 goes to the plc digital input let s see if we can find this wire

diagram wiring diagram panel listrik mydiagram online - Jun 04 2022

web aug 5 2023 wiring diagram panel listrik posted by panel listrik author 2023 08 05 cara membaca wiring diagram panel listrik cara membaca wiring diagram panel listrik instalasi listrik 3 phase untuk pemula

wiring diagram panel listrik 3 phase wiring work - Dec 30 2021

web oct 29 2020 a typical wiring diagram for a 3 phase electrical system includes a panel board main switch circuit breakers fused disconnect switches ground fault circuit interrupters and meter sockets the wires connecting the circuit breakers switches and sockets must be connected correctly in order for the system to work properly

wiring diagram panel listrik wiring digital and schematic - May 15 2023

web apr 19 2022 what is a wiring diagram panel listrik a wiring diagram panel listrik is a graphical representation of an electrical system it shows how the various components of the system fit together and how they work together the diagram consists of symbols that represent the electrical components of the system

belajar membuat wiring diagram dengan see electrical youtube - Apr 02 2022

web aug 17 2021 assalamu alaikum wr wb teman teman semua kali ini saya akan berbagi cara bagaimana membuat sebuah wiring diagram menggunakan see electrical ya bagi yg belum punya software silahkan download dulu

registered practical nurse rpn registration examinations cno - Apr 29 2022

web and targeted sample questions to help you put your expertise into practice apply the knowledge you ve gained in real life situations and face the exam with confidence in

rex pn sample questions examprephero - Mar 09 2023

web become a nurse examinations registered practical nurse rpn registration examinations preparing for the rex pn preparing for the rex pn the following are

rpn exam practice questions alberta tvl parisbytrain com - May 31 2022

web it is comprised of approximately 90 150 multiple choice questions currently the exam time limit is 4 hours it is a computerized exam offered in english or french at a pearson vue

rpn exam practice questions alberta pdf pdf - Oct 04 2022

web how to pass your pn exam exam questions preparation practice questions 1000 1500 questions list of the provincial and territorial nursing regulatory authorities

canadian practical nurse registration - Aug 14 2023

successfully passing the cpnre is the final step required for practical nursing students to obtain active registration with the clpna to be eligible to write this exam you must be a successful graduate of a practical nursing program in alberta or an internationally educated nurse who has been assessed by see more

rpn exam practice questions alberta pdf canadian nurses - Dec 26 2021

web april 26th 2018 alberta class 7 practice test questions and answers we offer free practice for signs and traffic rules test pass your alberta learner s permit test the first

regulatory exam practical nurse cno - Sep 22 2021

web rex pn frequently asked questions background and purpose what is the rex pn the regulatory exam practical nurse rex pn is an entry to practice exam for

pn exam for ien - Dec 06 2022

web welcome to the registered psychiatric nurse regulators of canada practice exam site official registered psychiatric nurse regulators of canada rpnrc online

rpn exam practice questions alberta secure4 khronos - Jan 27 2022

web member to buy and make bargains to download and install rpn exam practice questions alberta so simple nclex rn flashcard study system mometrix nursing certification

rpnce study guide practice test college of - Nov 05 2022

web 1 apply for registration with bccnm and accommodations if required 2 pay for the exam and select preferred writing location 3 wait for your exam booking confirmation fees

[sample exam questions cno](#) - Apr 10 2023

web 02 40 00 exam structure the following portion of the examination includes 1 case study the case study includes introductory information about a specific situation followed

[rpn exam practice questions alberta copy uniport edu](#) - Oct 24 2021

web may 28 2023 comprehending as capably as accord even more than supplementary will pay for each success next door to the proclamation as with ease as keenness of this

[preparing for the rex pn cno](#) - May 11 2023

web note this canadian practical nurse registration examination cpnre sample exam contains 20 questions each cpnre practice exam contains a total of 170 questions

[exam rpnce bccnm](#) - Jan 07 2023

web practical nursing rex pn practice questions sample rex pn flashcards sample rex pn study material rex pn practice exams cpnre sample questions cpnre

[rpn exam practice questions alberta tvl parisbytrain com](#) - Feb 25 2022

web print registered practical nurse rpn registration examinations before you can become a registered practical nurse rpn in ontario you must successfully complete a

rex pn frequently asked questions cno - Nov 24 2021

web jun 12 2023 rpn exam practice questions alberta crpnbc gt registration amp renewal homepage gt registration examination and practice test questions you can

rpn exam practice questions alberta copy uniport edu - Mar 29 2022

web april 26th 2018 alberta class 7 practice test questions and answers we offer free practice for signs and traffic rules test pass your alberta learner s permit test the first

exam structure scenario next ncasbc - Jun 12 2023

the cpnre predictor test is a tool designed to help you gauge how ready you are to take the canadian practical nurse registration examination cpnre and see more

[home rpn cetest prep ysasecure com](#) - Feb 08 2023

web 1 a father expresses concerns about his son s upcoming surgery and has several questions about the procedure the nurse listens to the father s concerns shares

cpnre sample questions examprephero - Jul 13 2023

accommodations are requests for various reasons related to a disability that is currently being treated by a physician or has been diagnosed and treated in the see more

rpn exam practice questions alberta database grovemade - Jul 01 2022

web aug 17 2023 mcmaster university campus room 104 1400 main street west hamilton on l8s 1c7 phone 905 575 1212 x6835

pn exam in canada - Aug 02 2022

web critical thinking questions that reflect canadian national licensing exams and address all question levels knowledge comprehension application analysis synthesis and

library guides practical nursing rpn exam prep - Sep 03 2022

web study guide the study guide assists internationally educated nurse applicants and canadian psychiatric nursing graduates who will be writing the registered psychiatric