

ENGINE

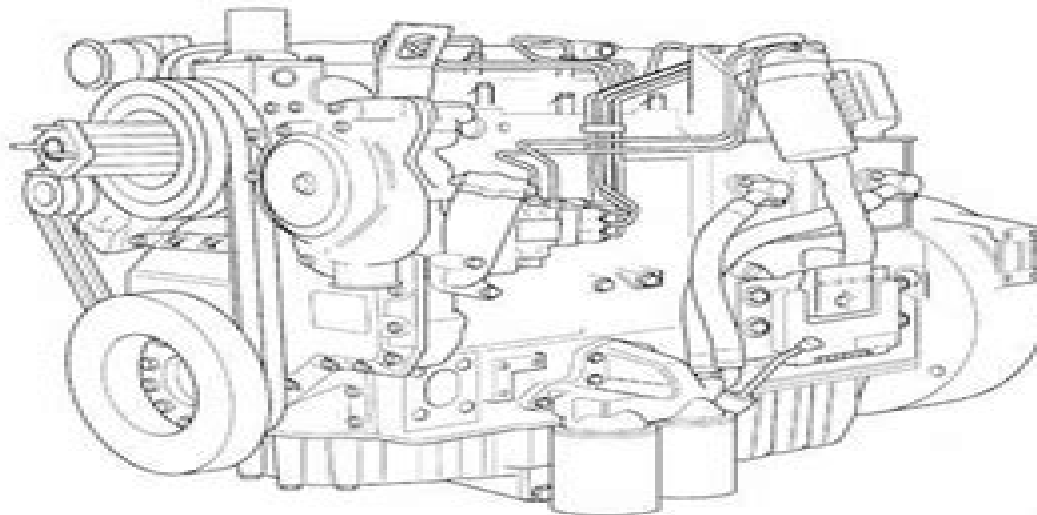

SERVICE MANUAL

Perkins®
1100 Series 6-Cylinder Diesel Engine



Perkins 42g Manual

Annelies Wilder-Smith



Perkins 42g Manual:

Yeah, reviewing a book **Perkins 42g Manual** could go to your near friends listings. This is just one of the solutions for you to be successful. As understood, deed does not suggest that you have wonderful points.

Comprehending as without difficulty as bargain even more than new will find the money for each success. bordering to, the message as capably as insight of this Perkins 42g Manual can be taken as with ease as picked to act.

https://crm.avenza.com/data/book-search/Download_PDFS/Odysseyware_Semester_English_Exam_Answers.pdf

Table of Contents Perkins 42g Manual

1. Understanding the eBook Perkins 42g Manual
 - The Rise of Digital Reading Perkins 42g Manual
 - Advantages of eBooks Over Traditional Books
2. Identifying Perkins 42g Manual
 - Exploring Different Genres
 - Considering Fiction vs. Non-Fiction
 - Determining Your Reading Goals
3. Choosing the Right eBook Platform
 - Popular eBook Platforms
 - Features to Look for in an Perkins 42g Manual
 - User-Friendly Interface
4. Exploring eBook Recommendations from Perkins 42g Manual
 - Personalized Recommendations
 - Perkins 42g Manual User Reviews and Ratings
 - Perkins 42g Manual and Bestseller Lists
5. Accessing Perkins 42g Manual Free and Paid eBooks
 - Perkins 42g Manual Public Domain eBooks
 - Perkins 42g Manual eBook Subscription Services

- Perkins 42g Manual Budget-Friendly Options
- 6. Navigating Perkins 42g Manual eBook Formats
 - ePub, PDF, MOBI, and More
 - Perkins 42g Manual Compatibility with Devices
 - Perkins 42g Manual Enhanced eBook Features
- 7. Enhancing Your Reading Experience
 - Adjustable Fonts and Text Sizes of Perkins 42g Manual
 - Highlighting and Note-Taking Perkins 42g Manual
 - Interactive Elements Perkins 42g Manual
- 8. Staying Engaged with Perkins 42g Manual
 - Joining Online Reading Communities
 - Participating in Virtual Book Clubs
 - Following Authors and Publishers Perkins 42g Manual
- 9. Balancing eBooks and Physical Books Perkins 42g Manual
 - Benefits of a Digital Library
 - Creating a Diverse Reading Collection Perkins 42g Manual
- 10. Overcoming Reading Challenges
 - Dealing with Digital Eye Strain
 - Minimizing Distractions
 - Managing Screen Time
- 11. Cultivating a Reading Routine Perkins 42g Manual
 - Setting Reading Goals Perkins 42g Manual
 - Carving Out Dedicated Reading Time
- 12. Sourcing Reliable Information of Perkins 42g Manual
 - Fact-Checking eBook Content of Perkins 42g Manual
 - Distinguishing Credible Sources
- 13. Promoting Lifelong Learning
 - Utilizing eBooks for Skill Development
 - Exploring Educational eBooks
- 14. Embracing eBook Trends

- Integration of Multimedia Elements
- Interactive and Gamified eBooks

Perkins 42g Manual Introduction

Perkins 42g Manual Offers over 60,000 free eBooks, including many classics that are in the public domain. Open Library: Provides access to over 1 million free eBooks, including classic literature and contemporary works. Perkins 42g Manual Offers a vast collection of books, some of which are available for free as PDF downloads, particularly older books in the public domain. Perkins 42g Manual : This website hosts a vast collection of scientific articles, books, and textbooks. While it operates in a legal gray area due to copyright issues, its a popular resource for finding various publications. Internet Archive for Perkins 42g Manual : Has an extensive collection of digital content, including books, articles, videos, and more. It has a massive library of free downloadable books. Free-eBooks Perkins 42g Manual Offers a diverse range of free eBooks across various genres. Perkins 42g Manual Focuses mainly on educational books, textbooks, and business books. It offers free PDF downloads for educational purposes. Perkins 42g Manual Provides a large selection of free eBooks in different genres, which are available for download in various formats, including PDF. Finding specific Perkins 42g Manual, especially related to Perkins 42g Manual, might be challenging as theyre often artistic creations rather than practical blueprints. However, you can explore the following steps to search for or create your own Online Searches: Look for websites, forums, or blogs dedicated to Perkins 42g Manual, Sometimes enthusiasts share their designs or concepts in PDF format. Books and Magazines Some Perkins 42g Manual books or magazines might include. Look for these in online stores or libraries. Remember that while Perkins 42g Manual, sharing copyrighted material without permission is not legal. Always ensure youre either creating your own or obtaining them from legitimate sources that allow sharing and downloading. Library Check if your local library offers eBook lending services. Many libraries have digital catalogs where you can borrow Perkins 42g Manual eBooks for free, including popular titles. Online Retailers: Websites like Amazon, Google Books, or Apple Books often sell eBooks. Sometimes, authors or publishers offer promotions or free periods for certain books. Authors Website Occasionally, authors provide excerpts or short stories for free on their websites. While this might not be the Perkins 42g Manual full book , it can give you a taste of the authors writing style. Subscription Services Platforms like Kindle Unlimited or Scribd offer subscription-based access to a wide range of Perkins 42g Manual eBooks, including some popular titles.

FAQs About Perkins 42g Manual Books

What is a Perkins 42g Manual PDF? A PDF (Portable Document Format) is a file format developed by Adobe that

preserves the layout and formatting of a document, regardless of the software, hardware, or operating system used to view or print it. **How do I create a Perkins 42g Manual PDF?** There are several ways to create a PDF: Use software like Adobe Acrobat, Microsoft Word, or Google Docs, which often have built-in PDF creation tools. Print to PDF: Many applications and operating systems have a "Print to PDF" option that allows you to save a document as a PDF file instead of printing it on paper. Online converters: There are various online tools that can convert different file types to PDF. **How do I edit a Perkins 42g Manual PDF?** Editing a PDF can be done with software like Adobe Acrobat, which allows direct editing of text, images, and other elements within the PDF. Some free tools, like PDFescape or Smallpdf, also offer basic editing capabilities. **How do I convert a Perkins 42g Manual PDF to another file format?** There are multiple ways to convert a PDF to another format: Use online converters like Smallpdf, Zamzar, or Adobe Acrobats export feature to convert PDFs to formats like Word, Excel, JPEG, etc. Software like Adobe Acrobat, Microsoft Word, or other PDF editors may have options to export or save PDFs in different formats. **How do I password-protect a Perkins 42g Manual PDF?** Most PDF editing software allows you to add password protection. In Adobe Acrobat, for instance, you can go to "File" -> "Properties" -> "Security" to set a password to restrict access or editing capabilities. Are there any free alternatives to Adobe Acrobat for working with PDFs? Yes, there are many free alternatives for working with PDFs, such as: LibreOffice: Offers PDF editing features. PDFsam: Allows splitting, merging, and editing PDFs. Foxit Reader: Provides basic PDF viewing and editing capabilities. How do I compress a PDF file? You can use online tools like Smallpdf, ILovePDF, or desktop software like Adobe Acrobat to compress PDF files without significant quality loss. Compression reduces the file size, making it easier to share and download. Can I fill out forms in a PDF file? Yes, most PDF viewers/editors like Adobe Acrobat, Preview (on Mac), or various online tools allow you to fill out forms in PDF files by selecting text fields and entering information. Are there any restrictions when working with PDFs? Some PDFs might have restrictions set by their creator, such as password protection, editing restrictions, or print restrictions. Breaking these restrictions might require specific software or tools, which may or may not be legal depending on the circumstances and local laws.

Find Perkins 42g Manual :

[odysseyware semester english exam answers](#)

[odyssey answer key for american government exam](#)

[ocr mark scheme june 2013 f211](#)

[official sat study guide for biology](#)

[of manual tread mill of engineering student](#)

[ocr maths cjune 2paper](#)

official railway guide 2013

ocr revision guide ppp6

ocr mei c1 june 2013 paper

ocr stats 1 june 12

oeuvres tertullien editions jm

office toy english edition

of mice and men film study guide

ocr mei fp1 may 2013 question paper

odyssey study guide guided questions and answers

Perkins 42g Manual :

Realidades Practice Workbook 3 - 1st Edition - Solutions ... Our resource for Realidades Practice Workbook 3 includes answers to chapter exercises, as well as detailed information to walk you through the process step by ... Realidades 3 Chapter 3 Flashcards Vocabulary Only Learn with flashcards, games, and more — for free. Realidades 3 Chapter 3 Que haces para estar en forma? Unit Overview. In Chapter 3, students will be introduced to additional common vocabulary, phrases and concepts related to. Realidades 3 chapter 3 - Teaching resources Realidades 3 chapter 3 · Examples from our community · 10000+ results for 'realidades 3 chapter 3' · Can't find it? Just make your own! Realidades 3 - Capítulo 3 - Profesora Dowden A ver si recuerdas. Quizlet: https://quizlet.com/_49gxbi. Capítulo 3 Vocabulario. Parte 1 Quizlet: https://quizlet.com/_4a7sie Realidades 3 capitulo 3 Browse realidades 3 capitulo 3 resources on Teachers Pay Teachers, a marketplace trusted by millions of teachers for original educational resources. Realidades 3 cap 3 vocabulario - Teaching resources Realidades 3 cap 3 vocabulario · Examples from our community · 10000+ results for 'realidades 3 cap 3 vocabulario' · Can't find it? Just make your own! Realidades 3 Capítulo 3 Parte 1 y 2 - Vocabulary Realidades 3 Capítulo 3 Parte 1 y 2 · Open Input · Multiple Choice · Conjugation Drill. Realidades 3, Cap. 3 - Vocabulario Java Games: Flashcards, matching, concentration, and word search. Realidades ... Realidades (3 May 2, 2009 — Realidades (3. Nombre. Capítulo 3. Fecha. Ser consejero(a). Hora. 15. Core Practice 3-11. ¿Puedes ayudar a los estudiantes que tienen problemas ... Medical Insurance Workbook Chapter 1 Answers.docx Medical Insurance Workbook Chapter 1 Answers Assignment 1.1 Review Questions 1.A.Hospitals, B.acute care hospitals, C.skilled nursing & long-term care ... Insurance Handbook For The Medical Office Flashcards Chapter -3 1-26 Learn with flashcards, games, and more — for free. 16IHMO Wk01 Ch01 worksheet Answerkey.pdf - Chapter 1 Answer routine inquiries related to account balances and insurance ... Insurance Billing Specialist Insurance Handbook for the Medical Office Workbook 9. Insurance Handbook for the Medical Office Chapter 3 ... Study with Quizlet and memorize

flashcards containing terms like Insurance Policy, Guarantor, List 5 health insurance policy renewal provisions and more. Workbook for Insurance Handbook for the Medical Office This user-friendly workbook features realistic, hands-on exercises to help you apply concepts and develop critical thinking skills. Study tools include ... Health insurance handbook : how to make it work (English) Health insurance handbook : how to make it work (English). Many countries that subscribe to the Millennium Development Goals (MDGs) have committed to ... Free Medical Flashcards about Insurance Handbook Study free Medical flashcards about Insurance Handbook created by FB to improve your grades. Matching game, word search puzzle, and hangman also available. Insurance Handbook The book begins with basic information on the various types of insurance, including auto, home, life, annuities and long-term care. A glossary section contains. Insurance Handbook for the Medical Office Oct 16, 2017 — Lesson 4.1 Documentation Basics Identify the most common documents found in the medical record. List the advantages and disadvantages of an ... Chapter 9 Insurance Answer Key Medical Insurance: A Revenue Cycle Process Approach. Read Book Insurance Handbook For The Medical Office Answer Key Chapter 9 Health insurance in the United ... Systems Understanding Aid by Alvin A. Arens... ... - Amazon Systems Understanding Aid by Alvin A. Arens and D. Dewey Ward. (Armond Dalton Publishers INC,2012) [Paperback] 8th Edition [Alvin Ward] on Amazon.com. Systems Understanding Aid by Alvin A. Arens and D... by AA Systems Understanding Aid by Alvin A. Arens and D. Dewey Ward 8th (eighth) Edition [Paperback(2012)] [AA] on Amazon.com. *FREE* shipping on qualifying ... Systems Understanding Aid A comprehensive manual accounting practice set that includes flowcharts, documents and internal controls. Uses a hands-on approach to help students understand ... Systems Understanding Aid | Rent - Chegg Systems Understanding Aid 8th edition ; Full Title: Systems Understanding Aid ; Edition: 8th edition ; ISBN-13: 978-0912503387 ; Format: Paperback/softback. solutions systems understanding aid 8th edition (PDF) May 16, 2023 — This is just one of the solutions for you to be successful. As understood, completion does not recommend that you have fabulous points ... Any tips for working through Systems Understanding Aid ... It took me a while to start, but the biggest piece of advice I can give you is learn what the flow charts mean and become familiar with them. Full completion of Systems Understanding Aid 8th edition ... Sep 19, 2016 — After the Systems Understanding Aid (SUA) is completed and graded, the SUA is yours to keep and use for future reference. You should mark up ... Textbook Bundles Systems Understanding Aid 10th Edition (2020) Arens and Ward (More info) ... 8th Edition (2016) Arens, Ward and Latham (More info) ». ISBN# 978-0-912503-60-8. Systems Understanding Aid 8th Edition - Ledgers Sep 15, 2016 — View Homework Help - Systems Understanding Aid 8th Edition -Ledgers from ACC 180 at Asheville-Buncombe Technical Community College.