

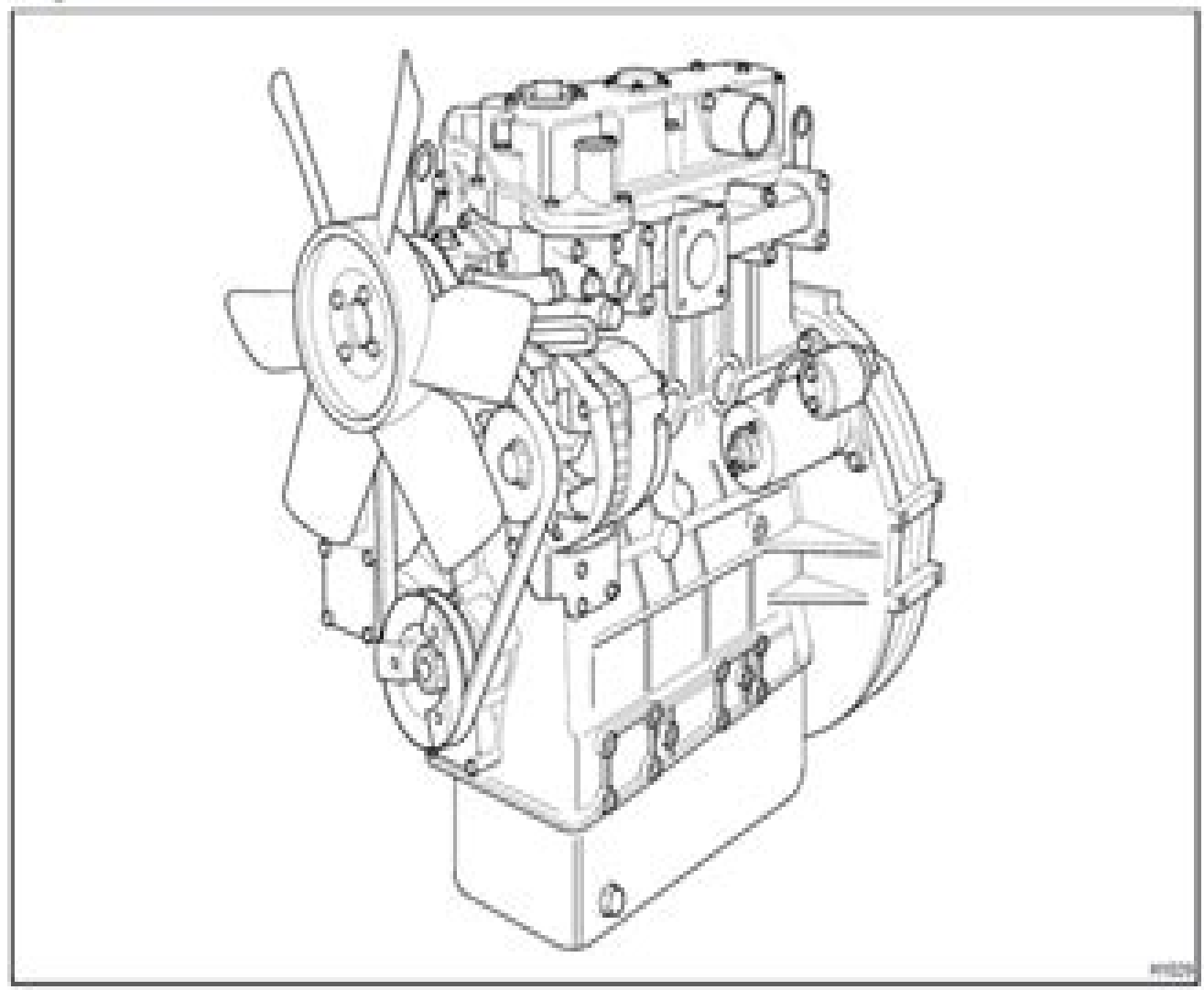

1

400 Series

Engine views



Perkins 400 Series Repair Manual

Lingjun Ying



Perkins 400 Series Repair Manual:

Thank you extremely much for downloading **Perkins 400 Series Repair Manual**. Maybe you have knowledge that, people have seen numerous times for their favorite books subsequent to this Perkins 400 Series Repair Manual, but end up in harmful downloads.

Rather than enjoying a good PDF gone a mug of coffee in the afternoon, then again they juggled past some harmful virus inside their computer. **Perkins 400 Series Repair Manual** is handy in our digital library an online entry to it is set as public as a result you can download it instantly. Our digital library saves in complex countries, allowing you to acquire the most less latency times to download any of our books next this one. Merely said, the Perkins 400 Series Repair Manual is universally compatible gone any devices to read.

https://crm.avenza.com/About/scholarship/fetch.php/Nfusion_Hd_Manual.pdf

Table of Contents Perkins 400 Series Repair Manual

1. Understanding the eBook Perkins 400 Series Repair Manual
 - The Rise of Digital Reading Perkins 400 Series Repair Manual
 - Advantages of eBooks Over Traditional Books
2. Identifying Perkins 400 Series Repair Manual
 - Exploring Different Genres
 - Considering Fiction vs. Non-Fiction
 - Determining Your Reading Goals
3. Choosing the Right eBook Platform
 - Popular eBook Platforms
 - Features to Look for in a Perkins 400 Series Repair Manual
 - User-Friendly Interface
4. Exploring eBook Recommendations from Perkins 400 Series Repair Manual
 - Personalized Recommendations
 - Perkins 400 Series Repair Manual User Reviews and Ratings

- Perkins 400 Series Repair Manual and Bestseller Lists
- 5. Accessing Perkins 400 Series Repair Manual Free and Paid eBooks
 - Perkins 400 Series Repair Manual Public Domain eBooks
 - Perkins 400 Series Repair Manual eBook Subscription Services
 - Perkins 400 Series Repair Manual Budget-Friendly Options
- 6. Navigating Perkins 400 Series Repair Manual eBook Formats
 - ePub, PDF, MOBI, and More
 - Perkins 400 Series Repair Manual Compatibility with Devices
 - Perkins 400 Series Repair Manual Enhanced eBook Features
- 7. Enhancing Your Reading Experience
 - Adjustable Fonts and Text Sizes of Perkins 400 Series Repair Manual
 - Highlighting and Note-Taking Perkins 400 Series Repair Manual
 - Interactive Elements Perkins 400 Series Repair Manual
- 8. Staying Engaged with Perkins 400 Series Repair Manual
 - Joining Online Reading Communities
 - Participating in Virtual Book Clubs
 - Following Authors and Publishers Perkins 400 Series Repair Manual
- 9. Balancing eBooks and Physical Books Perkins 400 Series Repair Manual
 - Benefits of a Digital Library
 - Creating a Diverse Reading Collection Perkins 400 Series Repair Manual
- 10. Overcoming Reading Challenges
 - Dealing with Digital Eye Strain
 - Minimizing Distractions
 - Managing Screen Time
- 11. Cultivating a Reading Routine Perkins 400 Series Repair Manual
 - Setting Reading Goals Perkins 400 Series Repair Manual
 - Carving Out Dedicated Reading Time
- 12. Sourcing Reliable Information of Perkins 400 Series Repair Manual
 - Fact-Checking eBook Content of Perkins 400 Series Repair Manual
 - Distinguishing Credible Sources

13. Promoting Lifelong Learning
 - Utilizing eBooks for Skill Development
 - Exploring Educational eBooks
14. Embracing eBook Trends
 - Integration of Multimedia Elements
 - Interactive and Gamified eBooks

Perkins 400 Series Repair Manual Introduction

In the digital age, access to information has become easier than ever before. The ability to download Perkins 400 Series Repair Manual has revolutionized the way we consume written content. Whether you are a student looking for course material, an avid reader searching for your next favorite book, or a professional seeking research papers, the option to download Perkins 400 Series Repair Manual has opened up a world of possibilities. Downloading Perkins 400 Series Repair Manual provides numerous advantages over physical copies of books and documents. Firstly, it is incredibly convenient. Gone are the days of carrying around heavy textbooks or bulky folders filled with papers. With the click of a button, you can gain immediate access to valuable resources on any device. This convenience allows for efficient studying, researching, and reading on the go. Moreover, the cost-effective nature of downloading Perkins 400 Series Repair Manual has democratized knowledge. Traditional books and academic journals can be expensive, making it difficult for individuals with limited financial resources to access information. By offering free PDF downloads, publishers and authors are enabling a wider audience to benefit from their work. This inclusivity promotes equal opportunities for learning and personal growth. There are numerous websites and platforms where individuals can download Perkins 400 Series Repair Manual. These websites range from academic databases offering research papers and journals to online libraries with an expansive collection of books from various genres. Many authors and publishers also upload their work to specific websites, granting readers access to their content without any charge. These platforms not only provide access to existing literature but also serve as an excellent platform for undiscovered authors to share their work with the world. However, it is essential to be cautious while downloading Perkins 400 Series Repair Manual. Some websites may offer pirated or illegally obtained copies of copyrighted material. Engaging in such activities not only violates copyright laws but also undermines the efforts of authors, publishers, and researchers. To ensure ethical downloading, it is advisable to utilize reputable websites that prioritize the legal distribution of content. When downloading Perkins 400 Series Repair Manual, users should also consider the potential security risks associated with online platforms. Malicious actors may exploit vulnerabilities in unprotected websites to distribute malware or steal personal information. To protect themselves, individuals should ensure their devices have reliable

antivirus software installed and validate the legitimacy of the websites they are downloading from. In conclusion, the ability to download Perkins 400 Series Repair Manual has transformed the way we access information. With the convenience, cost-effectiveness, and accessibility it offers, free PDF downloads have become a popular choice for students, researchers, and book lovers worldwide. However, it is crucial to engage in ethical downloading practices and prioritize personal security when utilizing online platforms. By doing so, individuals can make the most of the vast array of free PDF resources available and embark on a journey of continuous learning and intellectual growth.

FAQs About Perkins 400 Series Repair Manual Books

What is a Perkins 400 Series Repair Manual PDF? A PDF (Portable Document Format) is a file format developed by Adobe that preserves the layout and formatting of a document, regardless of the software, hardware, or operating system used to view or print it. **How do I create a Perkins 400 Series Repair Manual PDF?** There are several ways to create a PDF: Use software like Adobe Acrobat, Microsoft Word, or Google Docs, which often have built-in PDF creation tools. Print to PDF: Many applications and operating systems have a "Print to PDF" option that allows you to save a document as a PDF file instead of printing it on paper. Online converters: There are various online tools that can convert different file types to PDF. **How do I edit a Perkins 400 Series Repair Manual PDF?** Editing a PDF can be done with software like Adobe Acrobat, which allows direct editing of text, images, and other elements within the PDF. Some free tools, like PDFescape or Smallpdf, also offer basic editing capabilities. **How do I convert a Perkins 400 Series Repair Manual PDF to another file format?** There are multiple ways to convert a PDF to another format: Use online converters like Smallpdf, Zamzar, or Adobe Acrobat's export feature to convert PDFs to formats like Word, Excel, JPEG, etc. Software like Adobe Acrobat, Microsoft Word, or other PDF editors may have options to export or save PDFs in different formats. **How do I password-protect a Perkins 400 Series Repair Manual PDF?** Most PDF editing software allows you to add password protection. In Adobe Acrobat, for instance, you can go to "File" -> "Properties" -> "Security" to set a password to restrict access or editing capabilities. Are there any free alternatives to Adobe Acrobat for working with PDFs? Yes, there are many free alternatives for working with PDFs, such as: LibreOffice: Offers PDF editing features. PDFsam: Allows splitting, merging, and editing PDFs. Foxit Reader: Provides basic PDF viewing and editing capabilities. How do I compress a PDF file? You can use online tools like Smallpdf, ILovePDF, or desktop software like Adobe Acrobat to compress PDF files without significant quality loss. Compression reduces the file size, making it easier to share and download. Can I fill out forms in a PDF file? Yes, most PDF viewers/editors like Adobe Acrobat, Preview (on Mac), or various online tools allow you to fill out forms in PDF files by selecting text fields and entering information. Are there any restrictions when working with PDFs? Some PDFs might have

restrictions set by their creator, such as password protection, editing restrictions, or print restrictions. Breaking these restrictions might require specific software or tools, which may or may not be legal depending on the circumstances and local laws.

Find Perkins 400 Series Repair Manual :

[nfusion hd manual](#)

[new holland tractor tc45 service manual](#)

new holland tm 165 operators manual

[newmont quality manual iso 9001](#)

new wagon r service schedule

nfpa 21 codes 2 edition

new holland tractor manual for 4020

new sidecar harley motorcycles

[nfhs 20football test answers](#)

~~new home 632 sewing machine manual~~

[nex 3 manual](#)

new holland tsa manual

new york state social studies curriculum guide

nextest maverick manual

new holland tm 140 service manual

Perkins 400 Series Repair Manual :

California Real Estate Principles 15th Edition Walt Huber Real Estate Final Exam - 100 Questions. 100 terms. Profile Picture · lauramiy. Preview. California Real Estate Principles, 11th ed. 100 terms. Profile Picture. California Real Estate Principles Huber Final Exam California Real Estate Principles Huber Final Exam california-real-estate-principles-huber-final-exam. 5. Downloaded from usa.tgifridays.com on. 2022-08-30 by ... California Real Estate Principles Huber Final Exam Pdf California Real Estate Principles Huber Final Exam Pdf. INTRODUCTION California Real Estate Principles Huber Final Exam Pdf (PDF) How To Pass the California Real Estate Examination This Exam Preparation Textbook expands on the California Real Estate Principle's Class very well, and has 850 Questions with Detailed Answer Explanations. The ... Real Estate Principles Online

Course w/textbook California Real Estate Principles 16th Edition by Walt Huber. ISBN ... Completion of the course means taking and passing the course final examination. Once ... Principles Course Review for Final Exam - California Real ... Free read California real estate principles huber final exam ... May 8, 2023 — ... to scientific research in any way. in the middle of them is this california real estate principles huber final exam that can be your partner. RE 300 : Real Estate Principles - American River College Real Estate Principles FINAL EXAMINATION BOOKS 1. In real estate the word tenancy ... An example of a final exam in California License Preparation test. Real ... Read free California real estate principles huber final exam ... May 8, 2023 — Thank you very much for downloading california real estate principles huber final exam. Maybe you have knowledge that, people have look ... California Real Estate Principles, 11 th ed., by Walt Huber ... Real Estate Final Examination Practice El Camino College & Inglewood One Stop 1. The Effective Corrections Manager: ... Managing a correctional agency hinges on effectively recruiting, training, directing, and motivating people to provide a stable and safe correctional ... The Effective Corrections Manager The Effective Corrections Manager: Correctional Supervision for the Future, Third Edition covers all the major management topics required for those entering ... Effective Corrections Manager, 3rd Edition The Effective Corrections Manager: Correctional Supervision for the Future, Second Edition provides current information on management and supervision, and ... The Effective Corrections Manager:... by Phillips, Richard This authoritative reference covers all the necessary and relevant management areas at a level of detail that will be useful to all those working in prisons. The Effective Corrections Manager Oct 4, 2012 — Managing a correctional agency hinges on effectively recruiting, training, directing, and motivating people to provide a stable and safe ... The Effective Corrections Manager: ... Managing a correctional agency hinges on effectively recruiting, training, directing, and motivating people to provide a stable and safe correctional. 9781449645465 | Effective Corrections Oct 18, 2012 — Rent textbook Effective Corrections Manager Correctional Supervision for the Future by Gladwin, Bridget - 9781449645465. Price: \$98.72. The effective corrections manager of: The effective corrections manager : correctional supervision for the future / Richard L. Phillips, Charles. R. McConnell. 2nd ed. c2005. Includes ... The Effective Corrections Manager The Effective Corrections Manager: Correctional Supervision for the Future, Second Edition provides current information on management and supervision, and ... Correctional Supervision for the Future - Gladwin, Bridget ... Managing a correctional agency hinges on effectively recruiting, training, directing, and motivating people to provide a stable and safe correctional ... Blank Social Security Card Images Search from thousands of royalty-free Blank Social Security Card stock images and video for your next project. Download royalty-free stock photos, vectors, ... Blank Social Security Card Template - Free Printable Fake ... Get a free, printable Social Security Card template to easily create a realistic-looking fake social security card for novelty or educational purposes. Free Blank Social Security Card Template Download Free Blank Social Security Card Template Download. The remarkable Free Blank Social Security Card Template Download pics below, is segment of ... 12 Real & Fake

Social Security Card Templates (FREE) Aug 23, 2021 — Social Security number is a must and very important for all the citizens of America. You can download these social security card templates. Application for Social Security Card You must provide a current unexpired document issued to you by the Department of Homeland Security (DHS) showing your immigration status, such as Form I-551, I- ... Social security card template: Fill out & sign online Edit, sign, and share social sec cards template online. No need to install software, just go to DocHub, and sign up instantly and for free. Social Security Card Generator Form - Fill Out and Sign ... Social Security Card Maker. Check out how easy it is to complete and eSign documents online using fillable templates and a powerful editor. Pin on Card templates free Passport Template, Id Card Template, Templates Printable Free, Money Template, Visa Card. Document download Social Security. Document download Social Security. Blank Fillable Social Security Card Template - Fill Online ... Fill Blank Fillable Social Security Card Template, Edit online. Sign, fax and printable from PC, iPad, tablet or mobile with pdfFiller Instantly.