



Page Thumbnails



1

4000 Series

Engine view

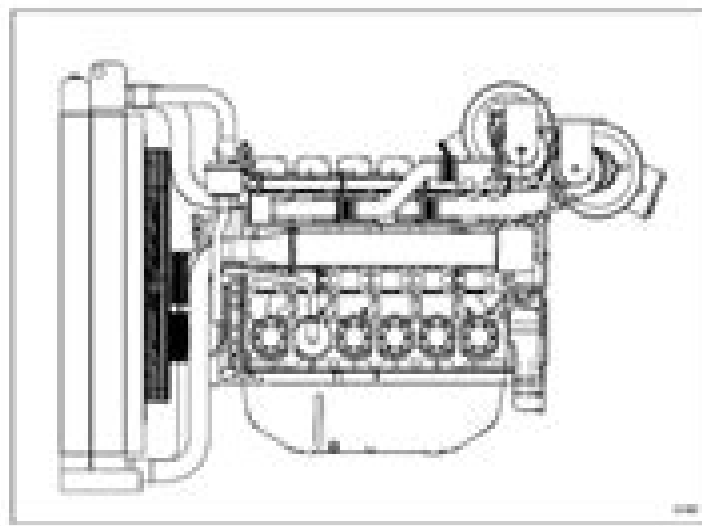
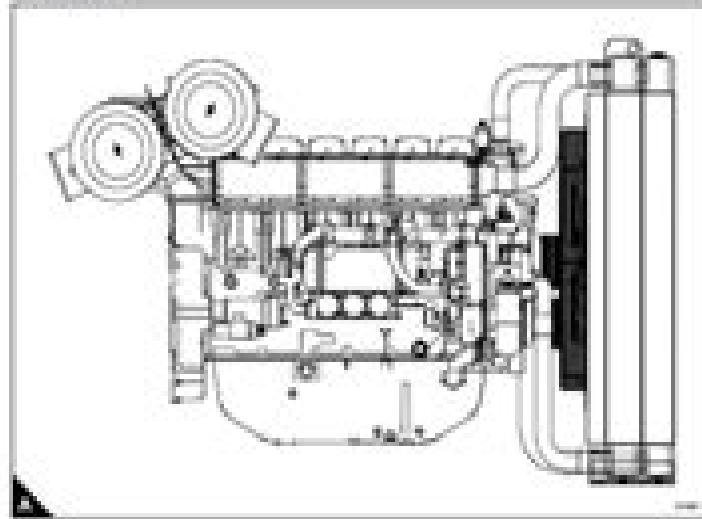

Perkins 4000 Series Electrical Service Manual

**Harwood Frost, Charles MacCaughey
Same**

Perkins 4000 Series Electrical Service Manual:

Adopting the Track of Appearance: An Psychological Symphony within **Perkins 4000 Series Electrical Service Manual**

In some sort of consumed by monitors and the ceaseless chatter of instantaneous connection, the melodic elegance and psychological symphony developed by the written term usually diminish into the back ground, eclipsed by the constant sound and interruptions that permeate our lives. Nevertheless, located within the pages of **Perkins 4000 Series Electrical Service Manual** a charming literary treasure overflowing with raw thoughts, lies an immersive symphony waiting to be embraced. Crafted by a wonderful musician of language, this fascinating masterpiece conducts visitors on a mental journey, well unraveling the concealed melodies and profound impact resonating within each cautiously crafted phrase. Within the depths with this touching review, we shall explore the book is main harmonies, analyze their enthralling writing type, and submit ourselves to the profound resonance that echoes in the depths of readers souls.

https://crm.avenza.com/book/book-search/HomePages/Question_Papers_Maths_Grade_11_September_2014.pdf

Table of Contents Perkins 4000 Series Electrical Service Manual

1. Understanding the eBook Perkins 4000 Series Electrical Service Manual
 - The Rise of Digital Reading Perkins 4000 Series Electrical Service Manual
 - Advantages of eBooks Over Traditional Books
2. Identifying Perkins 4000 Series Electrical Service Manual
 - Exploring Different Genres
 - Considering Fiction vs. Non-Fiction
 - Determining Your Reading Goals
3. Choosing the Right eBook Platform
 - Popular eBook Platforms
 - Features to Look for in an Perkins 4000 Series Electrical Service Manual
 - User-Friendly Interface
4. Exploring eBook Recommendations from Perkins 4000 Series Electrical Service Manual
 - Personalized Recommendations

- Perkins 4000 Series Electrical Service Manual User Reviews and Ratings
- Perkins 4000 Series Electrical Service Manual and Bestseller Lists
- 5. Accessing Perkins 4000 Series Electrical Service Manual Free and Paid eBooks
 - Perkins 4000 Series Electrical Service Manual Public Domain eBooks
 - Perkins 4000 Series Electrical Service Manual eBook Subscription Services
 - Perkins 4000 Series Electrical Service Manual Budget-Friendly Options
- 6. Navigating Perkins 4000 Series Electrical Service Manual eBook Formats
 - ePub, PDF, MOBI, and More
 - Perkins 4000 Series Electrical Service Manual Compatibility with Devices
 - Perkins 4000 Series Electrical Service Manual Enhanced eBook Features
- 7. Enhancing Your Reading Experience
 - Adjustable Fonts and Text Sizes of Perkins 4000 Series Electrical Service Manual
 - Highlighting and Note-Taking Perkins 4000 Series Electrical Service Manual
 - Interactive Elements Perkins 4000 Series Electrical Service Manual
- 8. Staying Engaged with Perkins 4000 Series Electrical Service Manual
 - Joining Online Reading Communities
 - Participating in Virtual Book Clubs
 - Following Authors and Publishers Perkins 4000 Series Electrical Service Manual
- 9. Balancing eBooks and Physical Books Perkins 4000 Series Electrical Service Manual
 - Benefits of a Digital Library
 - Creating a Diverse Reading Collection Perkins 4000 Series Electrical Service Manual
- 10. Overcoming Reading Challenges
 - Dealing with Digital Eye Strain
 - Minimizing Distractions
 - Managing Screen Time
- 11. Cultivating a Reading Routine Perkins 4000 Series Electrical Service Manual
 - Setting Reading Goals Perkins 4000 Series Electrical Service Manual
 - Carving Out Dedicated Reading Time
- 12. Sourcing Reliable Information of Perkins 4000 Series Electrical Service Manual
 - Fact-Checking eBook Content of Perkins 4000 Series Electrical Service Manual

- Distinguishing Credible Sources
- 13. Promoting Lifelong Learning
 - Utilizing eBooks for Skill Development
 - Exploring Educational eBooks
- 14. Embracing eBook Trends
 - Integration of Multimedia Elements
 - Interactive and Gamified eBooks

Perkins 4000 Series Electrical Service Manual Introduction

In this digital age, the convenience of accessing information at our fingertips has become a necessity. Whether its research papers, eBooks, or user manuals, PDF files have become the preferred format for sharing and reading documents. However, the cost associated with purchasing PDF files can sometimes be a barrier for many individuals and organizations. Thankfully, there are numerous websites and platforms that allow users to download free PDF files legally. In this article, we will explore some of the best platforms to download free PDFs. One of the most popular platforms to download free PDF files is Project Gutenberg. This online library offers over 60,000 free eBooks that are in the public domain. From classic literature to historical documents, Project Gutenberg provides a wide range of PDF files that can be downloaded and enjoyed on various devices. The website is user-friendly and allows users to search for specific titles or browse through different categories. Another reliable platform for downloading Perkins 4000 Series Electrical Service Manual free PDF files is Open Library. With its vast collection of over 1 million eBooks, Open Library has something for every reader. The website offers a seamless experience by providing options to borrow or download PDF files. Users simply need to create a free account to access this treasure trove of knowledge. Open Library also allows users to contribute by uploading and sharing their own PDF files, making it a collaborative platform for book enthusiasts. For those interested in academic resources, there are websites dedicated to providing free PDFs of research papers and scientific articles. One such website is Academia.edu, which allows researchers and scholars to share their work with a global audience. Users can download PDF files of research papers, theses, and dissertations covering a wide range of subjects. Academia.edu also provides a platform for discussions and networking within the academic community. When it comes to downloading Perkins 4000 Series Electrical Service Manual free PDF files of magazines, brochures, and catalogs, Issuu is a popular choice. This digital publishing platform hosts a vast collection of publications from around the world. Users can search for specific titles or explore various categories and genres. Issuu offers a seamless reading experience with its user-friendly interface and allows users to download PDF files for offline reading. Apart from dedicated platforms, search engines also play a crucial role in finding free PDF files. Google, for

instance, has an advanced search feature that allows users to filter results by file type. By specifying the file type as "PDF," users can find websites that offer free PDF downloads on a specific topic. While downloading Perkins 4000 Series Electrical Service Manual free PDF files is convenient, it's important to note that copyright laws must be respected. Always ensure that the PDF files you download are legally available for free. Many authors and publishers voluntarily provide free PDF versions of their work, but it's essential to be cautious and verify the authenticity of the source before downloading Perkins 4000 Series Electrical Service Manual. In conclusion, the internet offers numerous platforms and websites that allow users to download free PDF files legally. Whether it's classic literature, research papers, or magazines, there is something for everyone. The platforms mentioned in this article, such as Project Gutenberg, Open Library, Academia.edu, and Issuu, provide access to a vast collection of PDF files. However, users should always be cautious and verify the legality of the source before downloading Perkins 4000 Series Electrical Service Manual any PDF files. With these platforms, the world of PDF downloads is just a click away.

FAQs About Perkins 4000 Series Electrical Service Manual Books

1. Where can I buy Perkins 4000 Series Electrical Service Manual books? Bookstores: Physical bookstores like Barnes & Noble, Waterstones, and independent local stores. Online Retailers: Amazon, Book Depository, and various online bookstores offer a wide range of books in physical and digital formats.
2. What are the different book formats available? Hardcover: Sturdy and durable, usually more expensive. Paperback: Cheaper, lighter, and more portable than hardcovers. E-books: Digital books available for e-readers like Kindle or software like Apple Books, Kindle, and Google Play Books.
3. How do I choose a Perkins 4000 Series Electrical Service Manual book to read? Genres: Consider the genre you enjoy (fiction, non-fiction, mystery, sci-fi, etc.). Recommendations: Ask friends, join book clubs, or explore online reviews and recommendations. Author: If you like a particular author, you might enjoy more of their work.
4. How do I take care of Perkins 4000 Series Electrical Service Manual books? Storage: Keep them away from direct sunlight and in a dry environment. Handling: Avoid folding pages, use bookmarks, and handle them with clean hands. Cleaning: Gently dust the covers and pages occasionally.
5. Can I borrow books without buying them? Public Libraries: Local libraries offer a wide range of books for borrowing. Book Swaps: Community book exchanges or online platforms where people exchange books.
6. How can I track my reading progress or manage my book collection? Book Tracking Apps: Goodreads, LibraryThing,

and Book Catalogue are popular apps for tracking your reading progress and managing book collections. Spreadsheets: You can create your own spreadsheet to track books read, ratings, and other details.

7. What are Perkins 4000 Series Electrical Service Manual audiobooks, and where can I find them? Audiobooks: Audio recordings of books, perfect for listening while commuting or multitasking. Platforms: Audible, LibriVox, and Google Play Books offer a wide selection of audiobooks.
8. How do I support authors or the book industry? Buy Books: Purchase books from authors or independent bookstores. Reviews: Leave reviews on platforms like Goodreads or Amazon. Promotion: Share your favorite books on social media or recommend them to friends.
9. Are there book clubs or reading communities I can join? Local Clubs: Check for local book clubs in libraries or community centers. Online Communities: Platforms like Goodreads have virtual book clubs and discussion groups.
10. Can I read Perkins 4000 Series Electrical Service Manual books for free? Public Domain Books: Many classic books are available for free as they're in the public domain. Free E-books: Some websites offer free e-books legally, like Project Gutenberg or Open Library.

Find Perkins 4000 Series Electrical Service Manual :

question papers maths grade 11 september 2014

question paper of physics grade 10 september

quickswap with mefeminization gender swap erotica english edition

question paper business grade10 november 2013 caps

quiz 7 2 dividing monomials answer key

questions papers for november for grade 9 mpumalanga 2014

question paper maths grade 12

quiz questions about the lame man at lystra

questions of economics final exam for grade 10 p1

question paper of 5th sem

quick percent yield lab

question papers thermodynamics

quiz algebra 1 factoring polynomials form

quip english edition

question paper for november 2014 building and civil technology

Perkins 4000 Series Electrical Service Manual :

Solutions Manual for Java How To Program (Early Objects) ... Solutions Manual for Java How To Program (Early Objects), 10th Edition. Paul Deitel, Deitel & Associates, Inc. Harvey Deitel. ©2015 | Pearson. Harvey Deitel Solutions Manual for Java How to Program: Late Objects Version 8th Edition 365 ... C Student Solutions Manual to Accompany C How ... This is the Student Solutions Manual which accompanies C How to Program, 4th edition. It acts as a study guide providing a large number of completely solved ... Deitel & Deitel - "C How To Program" - solutions to exercises Deitel & Deitel - "C How To Program" - solutions to exercises. Intro. Here you can find my solutions for Deitel & Deitel - "C How To Program". C Student Solutions Manual to Accompany C How ... Synopsis: This is the Student Solutions Manual which accompanies C How to Program, 4th edition. It acts as a study guide providing a large number of completely ... Java Student Solutions Manual: To Accompany ... Java Student Solutions Manual: To Accompany Java How To Program [Deitel, Harvey M., Deitel, Paul J.] on Amazon.com. *FREE* shipping on qualifying offers. ydnAkif/Deitel: C++ How to Program 9th Edition Solutions Deitel. C++ How to Program 9th Edition Solutions. To run codes correctly, please download VsCode, Cmake and GCC or Clang compiler ... Objects Version, 7/E 7th Edition Paul Deitel, Harvey - Scribd Solution Manual for C++ How to Program: Late. Objects Version, 7/E 7th Edition Paul Deitel, Harvey. Deitel. To download the complete and accurate content ... Solution Manual for C How to Program, 7/E 7th - Scribd Solution Manual for C How to Program, 7/E 7th. Edition Paul Deitel, Harvey Deitel. To download the complete and accurate content document, go to:. C: How to Program - 7th Edition - Solutions and Answers Deitel, Paul J. ... At Quizlet, we're giving you the tools you need to take on any subject without having to carry around solutions manuals or printing out PDFs! Test Bank for Essentials of Investments - Full file at testbanku Full file at testbanku/ Test Bank for Essentials of Investments 9th Edition by Bodie Complete downloadable file at: testbanku/Test-Bank-for-Essentials-of ... Test Bank for Investments 9th Edition Bodie Kane Marcus View Test prep - Test Bank for Investments 9th Edition Bodie, Kane, Marcus from ECE 644 at New Jersey Institute Of Technology. Full file at. Investments Bodie Kane Marcus 9th Edition Test Bank Chapter 01 - The Investment Environment. Investments Bodie Kane Marcus 9th Edition Test. Bank full chapter at: <https://testbankbell.com/product/investments-> Test Bank for Essentials of Investments 9th Edition Bodie A. mutual fund shares. B. corporate equity. C. pension reserves. D. personal trusts. 8. Active trading in markets and competition among securities analysts ... Investment Solution Manuals & Test Bank Test Bank LTD has 100+ investment test bank or solution manuals. Now! Students do not need to worry about their exams. Instant Download at a low price. Essentials of Investments, Bodie - Complete test bank ... Mar 9, 2022 — Description: - Test bank with practice exam questions and their answers - Compatible with different editions (newer and older) - Various ... Question: essentials of investments 9th edition

test bank Jun 4, 2016 — Answer to essentials of investments 9th edition test bank. Essentials of Investments 12th Edition Bodie Exam Test ... Essentials of Investments 12th edition by Bodie exam and review test bank questions. Essentials of Investments, 9th Edition: 9780078034695: Zvi ... The market leading undergraduate investments textbook, Essentials of Investments, 9e by Bodie, Kane, and Marcus, emphasizes asset allocation while ... The Mixquiahuala Letters by Castillo, Ana The first novel by the noted Chicana poet, this is an epistolary novel in the tradition of Cortozor's Hopscotch. It focuses on the friendship between two strong ... The Mixquiahuala Letters by Ana Castillo Great book. A collection of letters from Teresa to her gringa friend throughout their travels and lives, from when they meet in Mexico into middle age. The ... The Mixquiahuala Letters (1986) - Ana Castillo Focusing on the relationship between two fiercely independent women—Teresa, a writer, and Alicia, an artist—this epistolary novel was written as a tribute ... The Mixquiahuala Letters - 1st Edition/1st Printing A handsome first edition/first printing in Fine condition. Signed and dated 2/24/94 by author Ana Castillo. The Mixquiahuala Letters tells the story of two ... The Mixquiahuala Letters Summary and Study Guide The Mixquiahuala Letters (1986) by Ana Castillo is a series of nonchronological, fictional letters from a poet named Teresa to her friend Alicia, an artist. Ana Castillo's "The Mixquiahuala Letters": A Queer "Don ... by BF Weissberger · 2007 · Cited by 1 — Ana Castillo's epistolary novel The Mixquiahuala Letters acknowledges its indebtedness to Don Quijote right at the start, in its playful prologue. The Mixquiahuala Letters by Ana Castillo This groundbreaking debut novel received an American Book Award from the Before Columbus Foundation and is widely studied as a feminist text on the nature of ... The Mixquiahuala Letters by Ana Castillo: 9780385420136 Mar 18, 1992 — Focusing on the relationship between two fiercely independent women—Teresa, a writer, and Alicia, an artist—this epistolary novel was written as ... The Mixquiahuala Letters Winner of the American Book Award from the Before Columbus Foundation, this epistolary novel focuses on the relationship between two strong and fiercely ... The Mixquiahuala Letters | novel by Castillo Written in an experimental form, the novel consists of letters sent over 10 years between two Latina women, arranged to be read in three different versions for ...