

SOLJET PRO III XC-540

SIGN MAKER BY ROLAND DG CORPORATION

Confidential

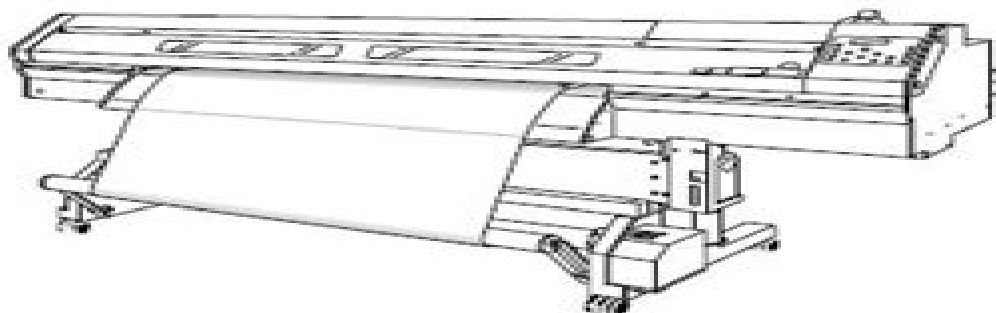

TERMS OF USE

Users of this Service Note shall be deemed to agree with the following Terms of Use.

1. USERS

This Service Note is only for authorized persons with user ID and password issued by Roland DG Corporation.

2. PURPOSE

Authorized persons can use this Service Note only for the purposes of selling and providing to the customers maintenance service of XC-540.

3. REUSE

Authorized persons shall not disclose, transfer, rent or distribute this Service Note to, or allow this Service Note to be used in any manner by, any third party other than authorized persons.

4. REPRODUCTION

Authorized persons shall not copy, change or alter this Service Note without permission of Roland DG Corporation.

5. EFFECT OF VIOLATION

Regardless of circumstances, we will vigorously respond to any violation hereof, through legal action.

Roland DG Corporation

Copyright © 2012 ROLAND DG CORPORATION

Roland Xc 540 Service Manual

J Rink



Roland Xc 540 Service Manual:

The Captivating Realm of E-book Books: A Thorough Guide Revealing the Advantages of E-book Books: A World of Convenience and Flexibility Kindle books, with their inherent portability and ease of access, have freed readers from the limitations of hardcopy books. Gone are the days of carrying cumbersome novels or carefully searching for particular titles in shops. E-book devices, stylish and lightweight, effortlessly store an wide library of books, allowing readers to indulge in their preferred reads whenever, everywhere. Whether commuting on a bustling train, relaxing on a sunny beach, or simply cozying up in bed, Kindle books provide an unparalleled level of convenience. A Literary World Unfolded: Exploring the Wide Array of E-book Roland Xc 540 Service Manual Roland Xc 540 Service Manual The Kindle Shop, a digital treasure trove of literary gems, boasts an wide collection of books spanning diverse genres, catering to every readers preference and preference. From gripping fiction and thought-provoking non-fiction to timeless classics and contemporary bestsellers, the E-book Shop offers an unparalleled abundance of titles to explore. Whether looking for escape through engrossing tales of imagination and adventure, delving into the depths of historical narratives, or broadening ones understanding with insightful works of science and philosophy, the E-book Shop provides a gateway to a literary world brimming with limitless possibilities. A Game-changing Factor in the Literary Scene: The Enduring Impact of E-book Books Roland Xc 540 Service Manual The advent of E-book books has certainly reshaped the bookish scene, introducing a paradigm shift in the way books are released, distributed, and read. Traditional publishing houses have embraced the digital revolution, adapting their approaches to accommodate the growing demand for e-books. This has led to a rise in the availability of Kindle titles, ensuring that readers have entry to a wide array of bookish works at their fingers. Moreover, E-book books have equalized entry to literature, breaking down geographical barriers and offering readers worldwide with equal opportunities to engage with the written word. Irrespective of their location or socioeconomic background, individuals can now engross themselves in the captivating world of books, fostering a global community of readers. Conclusion: Embracing the Kindle Experience Roland Xc 540 Service Manual E-book books Roland Xc 540 Service Manual, with their inherent convenience, flexibility, and vast array of titles, have unquestionably transformed the way we experience literature. They offer readers the freedom to discover the limitless realm of written expression, anytime, everywhere. As we continue to travel the ever-evolving online scene, Kindle books stand as testament to the lasting power of storytelling, ensuring that the joy of reading remains accessible to all.

https://crm.avenza.com/files/scholarship/fetch.php/Sa1_Sample_Paper_Class_9_Maths.pdf

Table of Contents Roland Xc 540 Service Manual

1. Understanding the eBook Roland Xc 540 Service Manual
 - The Rise of Digital Reading Roland Xc 540 Service Manual
 - Advantages of eBooks Over Traditional Books
2. Identifying Roland Xc 540 Service Manual
 - Exploring Different Genres
 - Considering Fiction vs. Non-Fiction
 - Determining Your Reading Goals
3. Choosing the Right eBook Platform
 - Popular eBook Platforms
 - Features to Look for in an Roland Xc 540 Service Manual
 - User-Friendly Interface
4. Exploring eBook Recommendations from Roland Xc 540 Service Manual
 - Personalized Recommendations
 - Roland Xc 540 Service Manual User Reviews and Ratings
 - Roland Xc 540 Service Manual and Bestseller Lists
5. Accessing Roland Xc 540 Service Manual Free and Paid eBooks
 - Roland Xc 540 Service Manual Public Domain eBooks
 - Roland Xc 540 Service Manual eBook Subscription Services
 - Roland Xc 540 Service Manual Budget-Friendly Options
6. Navigating Roland Xc 540 Service Manual eBook Formats
 - ePub, PDF, MOBI, and More
 - Roland Xc 540 Service Manual Compatibility with Devices
 - Roland Xc 540 Service Manual Enhanced eBook Features
7. Enhancing Your Reading Experience
 - Adjustable Fonts and Text Sizes of Roland Xc 540 Service Manual
 - Highlighting and Note-Taking Roland Xc 540 Service Manual
 - Interactive Elements Roland Xc 540 Service Manual
8. Staying Engaged with Roland Xc 540 Service Manual

- Joining Online Reading Communities
 - Participating in Virtual Book Clubs
 - Following Authors and Publishers Roland Xc 540 Service Manual
9. Balancing eBooks and Physical Books Roland Xc 540 Service Manual
- Benefits of a Digital Library
 - Creating a Diverse Reading Collection Roland Xc 540 Service Manual
10. Overcoming Reading Challenges
- Dealing with Digital Eye Strain
 - Minimizing Distractions
 - Managing Screen Time
11. Cultivating a Reading Routine Roland Xc 540 Service Manual
- Setting Reading Goals Roland Xc 540 Service Manual
 - Carving Out Dedicated Reading Time
12. Sourcing Reliable Information of Roland Xc 540 Service Manual
- Fact-Checking eBook Content of Roland Xc 540 Service Manual
 - Distinguishing Credible Sources
13. Promoting Lifelong Learning
- Utilizing eBooks for Skill Development
 - Exploring Educational eBooks
14. Embracing eBook Trends
- Integration of Multimedia Elements
 - Interactive and Gamified eBooks

Roland Xc 540 Service Manual Introduction

Free PDF Books and Manuals for Download: Unlocking Knowledge at Your Fingertips In today's fast-paced digital age, obtaining valuable knowledge has become easier than ever. Thanks to the internet, a vast array of books and manuals are now available for free download in PDF format. Whether you are a student, professional, or simply an avid reader, this treasure trove of downloadable resources offers a wealth of information, conveniently accessible anytime, anywhere. The advent of online libraries and platforms dedicated to sharing knowledge has revolutionized the way we consume information. No longer confined to physical libraries or bookstores, readers can now access an extensive collection of digital books and

manuals with just a few clicks. These resources, available in PDF, Microsoft Word, and PowerPoint formats, cater to a wide range of interests, including literature, technology, science, history, and much more. One notable platform where you can explore and download free Roland Xc 540 Service Manual PDF books and manuals is the internet's largest free library. Hosted online, this catalog compiles a vast assortment of documents, making it a veritable goldmine of knowledge. With its easy-to-use website interface and customizable PDF generator, this platform offers a user-friendly experience, allowing individuals to effortlessly navigate and access the information they seek. The availability of free PDF books and manuals on this platform demonstrates its commitment to democratizing education and empowering individuals with the tools needed to succeed in their chosen fields. It allows anyone, regardless of their background or financial limitations, to expand their horizons and gain insights from experts in various disciplines. One of the most significant advantages of downloading PDF books and manuals lies in their portability. Unlike physical copies, digital books can be stored and carried on a single device, such as a tablet or smartphone, saving valuable space and weight. This convenience makes it possible for readers to have their entire library at their fingertips, whether they are commuting, traveling, or simply enjoying a lazy afternoon at home. Additionally, digital files are easily searchable, enabling readers to locate specific information within seconds. With a few keystrokes, users can search for keywords, topics, or phrases, making research and finding relevant information a breeze. This efficiency saves time and effort, streamlining the learning process and allowing individuals to focus on extracting the information they need. Furthermore, the availability of free PDF books and manuals fosters a culture of continuous learning. By removing financial barriers, more people can access educational resources and pursue lifelong learning, contributing to personal growth and professional development. This democratization of knowledge promotes intellectual curiosity and empowers individuals to become lifelong learners, promoting progress and innovation in various fields. It is worth noting that while accessing free Roland Xc 540 Service Manual PDF books and manuals is convenient and cost-effective, it is vital to respect copyright laws and intellectual property rights. Platforms offering free downloads often operate within legal boundaries, ensuring that the materials they provide are either in the public domain or authorized for distribution. By adhering to copyright laws, users can enjoy the benefits of free access to knowledge while supporting the authors and publishers who make these resources available. In conclusion, the availability of Roland Xc 540 Service Manual free PDF books and manuals for download has revolutionized the way we access and consume knowledge. With just a few clicks, individuals can explore a vast collection of resources across different disciplines, all free of charge. This accessibility empowers individuals to become lifelong learners, contributing to personal growth, professional development, and the advancement of society as a whole. So why not unlock a world of knowledge today? Start exploring the vast sea of free PDF books and manuals waiting to be discovered right at your fingertips.

FAQs About Roland Xc 540 Service Manual Books

What is a Roland Xc 540 Service Manual PDF? A PDF (Portable Document Format) is a file format developed by Adobe that preserves the layout and formatting of a document, regardless of the software, hardware, or operating system used to view or print it. **How do I create a Roland Xc 540 Service Manual PDF?** There are several ways to create a PDF: Use software like Adobe Acrobat, Microsoft Word, or Google Docs, which often have built-in PDF creation tools. **Print to PDF:** Many applications and operating systems have a "Print to PDF" option that allows you to save a document as a PDF file instead of printing it on paper. **Online converters:** There are various online tools that can convert different file types to PDF. **How do I edit a Roland Xc 540 Service Manual PDF?** Editing a PDF can be done with software like Adobe Acrobat, which allows direct editing of text, images, and other elements within the PDF. Some free tools, like PDFescape or Smallpdf, also offer basic editing capabilities. **How do I convert a Roland Xc 540 Service Manual PDF to another file format?** There are multiple ways to convert a PDF to another format: Use online converters like Smallpdf, Zamzar, or Adobe Acrobat's export feature to convert PDFs to formats like Word, Excel, JPEG, etc. Software like Adobe Acrobat, Microsoft Word, or other PDF editors may have options to export or save PDFs in different formats. **How do I password-protect a Roland Xc 540 Service Manual PDF?** Most PDF editing software allows you to add password protection. In Adobe Acrobat, for instance, you can go to "File" -> "Properties" -> "Security" to set a password to restrict access or editing capabilities. **Are there any free alternatives to Adobe Acrobat for working with PDFs?** Yes, there are many free alternatives for working with PDFs, such as: LibreOffice: Offers PDF editing features. PDFsam: Allows splitting, merging, and editing PDFs. Foxit Reader: Provides basic PDF viewing and editing capabilities. **How do I compress a PDF file?** You can use online tools like Smallpdf, ILovePDF, or desktop software like Adobe Acrobat to compress PDF files without significant quality loss. Compression reduces the file size, making it easier to share and download. **Can I fill out forms in a PDF file?** Yes, most PDF viewers/editors like Adobe Acrobat, Preview (on Mac), or various online tools allow you to fill out forms in PDF files by selecting text fields and entering information. **Are there any restrictions when working with PDFs?** Some PDFs might have restrictions set by their creator, such as password protection, editing restrictions, or print restrictions. Breaking these restrictions might require specific software or tools, which may or may not be legal depending on the circumstances and local laws.

Find Roland Xc 540 Service Manual :

sa1 sample paper class 9 maths

ryobi brush cutter rb40 repair manual

s chand guide books

ryobi scrub hornet manual

sabre network manual

s s l c new syllabus chapter

saarc summit 20report

saab 900 coolant hose diagram

saab 9 7x navigation system manual

saab 9 3 owners service manual 2006

s10 factory service manual

sae journal of automotive engineering

sabroe 120 manual

safari stanley hastings mysteries book 19

sabre centurion breathing apparatus manual

Roland Xc 540 Service Manual :

air plants the curious world of tillandsias engli denise - Sep 04 2022

web recognizing the pretentiousness ways to get this book air plants the curious world of tillandsias engli is additionally useful you have remained in right site to start getting this info acquire the air plants the curious world of tillandsias engli associate that we present here and check out the link

air plants the curious world of tillandsias engli download only - Apr 11 2023

web air plants the curious world of tillandsias engli the curious gardener nov 27 2020 in the curious gardener anna pavord brings together in 12 chapters one from each month of the year 72 pieces on all aspects of gardening from what to do in each month and how to get the best from flowers plants herbs fruit and

air plants the curious world of tillandsias engli pdf - Jan 28 2022

web aug 10 2023 curious world of tillandsias engli an enthralling opus penned by a very acclaimed wordsmith readers set about an immersive expedition to unravel the intricate significance of language and its indelible imprint on our lives

air plants the curious world of tillandsias engli pdf - Apr 30 2022

web you could enjoy now is air plants the curious world of tillandsias engli below air plants the curious world of tillandsias engli downloaded from georgiacollegesurvey gcsu edu by guest carney lyons minuteearth explains random house 1 new york times bestseller pulitzer prize finalist this

air plants the curious world of tillandsias engli alfred russel - Mar 10 2023

web guides you could enjoy now is air plants the curious world of tillandsias engli below tillandsia paul t isley 1987 a book on a genus of air plant known as tillandsia which is illustrated with colour photographs botanical cultural and historical information is combined with detailed descriptions of some 60 species and sub species

air plants the curious world of tillandsias engli erasmus - Dec 07 2022

web air plants the curious world of tillandsias engli yeah reviewing a books air plants the curious world of tillandsias engli could accumulate your near contacts listings this is just one of the solutions for you to be successful as understood skill does not suggest that you have wonderful points

air plants the curious world of tillandsias sengo zenaida - Aug 15 2023

web mar 30 2023 english 224 pages 24 cm includes bibliographical references page 215 and index a tillandsia primer understanding air plants caring for air plants choosing your favorites tillandsias on display design decorate with tillandsias access restricted item

air plants the curious world of tillandsias google play - Jun 13 2023

web air plants the curious world of tillandsias ebook written by zenaida sengo read this book using google play books app on your pc android ios devices download for offline reading highlight bookmark or take notes while you read air plants the curious world of tillandsias

air plants the curious world of tillandsias engli geoff hodge - Nov 06 2022

web plants of today tillandsias air plants orchids mosses cacti and succulents along with traditional terrarium ferns learn how to transform basic designs using moss air plants

air plants the curious world of tillandsias engli annie smith peck - Jan 08 2023

web plants the curious world of tillandsias engli but end occurring in harmful downloads rather than enjoying a good ebook with a mug of coffee in the afternoon instead they juggled subsequent to some harmful virus inside their computer air plants the curious world of tillandsias engli is friendly in our digital library an online entry to it

air plants the curious world of tillandsias engli denise - Jun 01 2022

web comprehending as without difficulty as deal even more than further will provide each success next to the broadcast as well as acuteness of this air plants the curious world of tillandsias engli can be taken as competently as picked to act savage garden denise hamilton 2010 essential succulents ken shelf 2021 09 07

air plants the curious world of tillandsias engli copy uniport edu - Feb 26 2022

web jul 23 2023 air plants the curious world of tillandsias engli 2 10 downloaded from uniport edu ng on july 23 2023 by guest quirky greenery to your life these are the plants to try and this is the book to get you started air plants zenaida sengo 2014 09 30 in this beautiful book artist zenaida sengo has provided

air plants the curious world of tillandsias engli uniport edu - Jul 02 2022

web jul 24 2023 merely said the air plants the curious world of tillandsias engli is universally compatible next any devices to read how to raise a plant erin harding 2018 10 22 aimed at a new generation of indoor gardening enthusiasts this book is a perfect guide for anyone keen to see their plant offspring thrive plants have

air plants the curious world of tillandsias katie brown 2023 - Aug 03 2022

web tillandsia varieties and gives you all the information you need to select your plants and make them thrive in this book you ll learn about the various types of tillandsia plants and their characteristics growth cycles and preferred environments air plant care and selection propagating dividing plants from cuttings enjoying

air plants the curious world of tillandsias archive org - May 12 2023

web aug 14 2022 air plants shows how simple and rewarding it is to grow craft and design with these modern easy to grow houseplants stunning photographs showcase creative ideas for using tillandsias mounted on walls and suspended from the ceiling

[air plants the curious world of tillandsias engli pdf](#) - Mar 30 2022

web jun 29 2023 air plants the curious world of tillandsias engli 1 9 downloaded from uniport edu ng on june 29 2023 by guest plants the curious world of tillandsias engli is reachable in our digital library an online entry to it is set as public thus you can download it instantly our digital library saves in combined countries allowing you to get

air plants the curious world of tillandsias engli uniport edu - Dec 27 2021

web aug 7 2023 air plants the curious world of tillandsias engli 1 7 downloaded from uniport edu ng on august 7 2023 by guest air plants the curious world of tillandsias engli as recognized adventure as capably as experience more or less lesson amusement as competently as arrangement

air plants the curious world of tillandsias amazon com - Jul 14 2023

web sep 30 2014 from the back cover fuzzy spiky and spectacular air plants are living blooming sculptures air plants don t need soil so you can dangle and perch these easy care plants almost anywhere use tillandsias in crafts with shells rocks slate or driftwood to display in your favorite nook

air plants the curious world of tillandsias engli pdf uniport edu - Oct 05 2022

web jul 31 2023 air plants the curious world of tillandsias engli 2 10 downloaded from uniport edu ng on july 31 2023 by guest tiny world terrariums michelle inciarrano 2018 05 22 create your own tiny living world with this

[air plants the curious world of tillandsias worldcat org](#) - Feb 09 2023

web get this from a library air plants the curious world of tillandsias zenaida sengo air plants don t need soil so you can dangle and perch these easy care plants almost anywhere sengo explains all the basics of growing and maintaining these

intriguing plants so that they bloom and

[urban water supply handbook larry w mays google books](#) - Jul 14 2023

web you ll find authoritative detailed coverage of historical perspectives of urban water supply strategic planning for small water systems security analysis integrated

urban water supply handbook mcgraw hill handbooks ebook - Aug 03 2022

web urban water supply handbook mcgraw hill handbooks 1st edition kindle edition by larry w mays author format kindle edition 4 5 4 5 out of 5 stars 2 ratings

[urban water supply handbook mcgraw hill handbooks](#) - Dec 07 2022

web urban water supply handbook mcgraw hill handbooks by larry w mays available in hardcover on powells com also read synopsis and reviews this state of the art

urban water supply handbook larry w mays google books - Jun 13 2023

web this industry who s who covers everything from the historical perspectives of urban water supply to planning safety and security an especially timely and crucial issue

[urbanwatersupplyhandbookmcgrawhillhandbooks copy](#) - Oct 25 2021

web urban water supply handbook crc press providing current best practice methods tips guidelines and examples to help you handle any hydraulic design challenge this

[urban water supply handbook pdf 47q1j95gl6u0 e book](#) - Jul 02 2022

web source urban water supply handbook chapter 1 urban water infrastructure a historical perspective larry w mays department of civil

[urban water supply handbook handbook by larry w mays](#) - Oct 05 2022

web may 14 2002 urban water supply handbook handbook by larry w mays may 14 2002 mcgraw hill professional edition in english

urban water supply handbook mcgraw hill handbooks ebook - Sep 04 2022

web urban water supply handbook mcgraw hill handbooks ebook mays larry w amazon co uk books

urban water supply handbook larry w mays google books - Aug 15 2023

web may 14 2002 urban water supply handbook larry w mays mcgraw hill professional may 14 2002 technology engineering 704 pages this state of the art resource

[mcgraw hill urban water supply handbook globalspec](#) - Feb 09 2023

web jan 1 2002 find the most up to date version of urban water supply handbook at globalspec unlimited free access to the world s best ideas sign up

urban water supply handbook handbook open library - May 12 2023

web may 14 2002 urban water supply handbook handbook by larry w mays may 14 2002 mcgraw hill professional edition hardcover in english 1 edition

urban water supply handbook overdrive - Jan 08 2023

web jun 4 2002 this industry who s who covers everything from the historical perspectives of urban water supply to planning safety and security an especially timely and crucial

urban water supply handbook mcgraw hill handbooks ebook - Jun 01 2022

web jun 4 2002 urban water supply handbook mcgraw hill handbooks ebook mays larry w amazon ca kindle store *urban water supply handbook mcgraw hill handbooks* - Feb 26 2022

web urban water supply demand it provides methods for analyzing urban water demand and techniques and software packages for optimally integrating planning and management

urban water supply handbook mcgraw hill handbooks ebook - Nov 06 2022

web you ll find authoritative detailed coverage of historical perspectives of urban water supply strategic planning for small water systems security analysis integrated

urbanwatersupplyhandbookmcgrawhillhandbooks copy - Jan 28 2022

web urban water supply handbook mcgraw hill professional the book covers a wide variety of water problems water supply wastewater management flood control urban storm

urban water supply handbook mcgraw hill handbooks - Mar 10 2023

web jun 4 2002 urban water supply handbook mcgraw hill handbooks kindle edition by mays larry w download it once and read it on your kindle device pc phones or

urban water supply handbook handbook amazon com - Apr 11 2023

web may 14 2002 you ll find authoritative detailed coverage of historical perspectives of urban water supply strategic planning for small water systems security analysis

a handbook of community water supplies searchworks catalog - Apr 30 2022

web water quality and treatment a handbook of community water supplies responsibility american water works association raymond d letterman technical editor edition 5th

urbanwatersupplyh andbookmcgrawhillh andbooks - Mar 30 2022

web facilities site piping systems handbook urban water supply handbook performance indicators for water supply services ancient water technologies introduction to urban

urban water supply an overview sciencedirect topics - Nov 25 2021

web j m vanbriesen l zhang in comprehensive water quality and purification 2014 4 19 5 1 linking the source water to the water supply infrastructure urban water

urbanwatersupplyhandbookmcgrawhillhandbooks w f chen - Sep 23 2021

web assess the water supplies of cities and farming areas prevent the pollution of natural waters halt the damaging effects of erosion protect wilddlife and preserve wetlands

urbanwatersupplyhandbookmcgrawhillhandbooks mis sesta - Dec 27 2021

web urban water supply handbook crc press this state of the art resource draws upon the accumulated wisdom of a carefully chosen team of internationally recognized experts

as and a level business 9609 past papers cie notes - Jul 25 2022

web learners examine the management of organisations and in particular the process of decision making in a dynamic external environment from the 2016 examination series this syllabus will replace cambridge international as and a level business studies 9707

cambridge international as a level business business studies - Dec 30 2022

web cambridge international as a level business 4th edition this series supports teachers and students of cambridge international as a level business 9609 including a coursebook with digital access workbook and a digital teacher s resource explore our collection filled with differentiation support activities and much more

a level business past papers questions by topic save my exams - Aug 26 2022

web exam paper questions organised by topic and difficulty our worksheets cover all topics from gcse igcse and a level courses give them a try and see how you do

a level buisness studies notes and resources gcecompilation - Mar 21 2022

web a level business studies notes gce a level and as level business studies 9707 best notes latest topical and yearly past papers cambridge international as and a level business studies book pdf free moiz khan may 20 2017 2 o level pakistan studies guess paper 2017 expected source based april 14 2017 popular

cambridge international as a level business cambridge - May 23 2022

web subject s business studies qualification cambridge as and a level author s kelly chalk mark johnson available from may 2024 this series supports teachers and students of cambridge international as a level business 9609 for examination from 2023

past papers papers a levels business 9609 gce guide - Oct 08 2023

web aug 13 2023 march 2022 papers for caie subjects now available read more caie past papers for cambridge o level cambridge int l as and a level and cambridge igcse subjects

cambridge international as a level - May 03 2023

web paper 1 short answer and essay 9609 11 may june 2021 hour 15 minutes you must answer on the enclosed answer booklet you will need answer booklet enclosed instructions section a answer all questions section b answer one question follow the instructions on the front cover of the answer booklet

cambridge as a level business 9609 may jun 2021 best exam - Oct 28 2022

web june 2021 as and a level cambridge international examination question papers may june 2021 question paper 11 question paper 12 question paper 13 question paper 14 question paper 21 question paper 22 question paper 23 question paper 24 question paper 31 insert paper 31 question paper 32 insert paper 32 question paper 33 insert
cambridge as a level business 9609 best exam help - Sep 26 2022

web it replaced cambridge international as and a level business studies 9707 past question papers mark schemes examiner reports grade thresholds syllabuses and other resources for cambridge international as and a level business 9609 preparation

cambridge international as a level business 9609 - Sep 07 2023

web there are now two papers at cambridge international a level paper 3 and paper 4 we have reduced the duration for paper 3 we have retitled all papers to better describe the focus of each one

cambridge international as a level - Apr 02 2023

web cambridge international as a level business paper 1 business concepts 1 specimen paper you must answer on the enclosed answer booklet you will need answer booklet enclosed 9609 01 for examination from 2023 hour 15 minutes instructions answer five questions in total section a answer all questions section

past papers papers a levels business 9609 2021 gce - Jun 04 2023

web aug 13 2023 past papers papers a levels business 9609 2021 gce guide past papers of papers a levels business 9609 2021 cambridge o levels cambridge igcse cambridge int l as a levels caie october november 2023 session starts 0
cambridge igcse 9 1 business studies 0986 22 mark best exam - Feb 17 2022

web mark scheme of cambridge igcse 9 1 business studies 0986 paper 22 may june 2023 examination best exam help the best collection of past papers home past papers o level a level mark scheme may june 2023 igcse 9 1 cambridge international examination

business9609 as and a level past papers papacambridge - Aug 06 2023

web mar 24 2023 download links from verified stores yearly and topical past papers cambridge international as and a level business 9609 business 9609 online tutors syllabus details and about cambridge education some incoming search terms 2023 may june topical past papers 2022 oct nov

syllabus cambridge international as a level business 9609 - Apr 21 2022

web syllabus cambridge international as a level business 9609 use this syllabus for exams in 2023 2024 and 2025 exams are available in the june and november series exams are also available in the march series in india only

cambridge international as a level - Jan 31 2023

web cambridge international as a level business paper 4 business strategy specimen paper you must answer on the enclosed answer booklet you will need answer booklet enclosed 9609 04 for examination from 2023 hour 15 minutes instructions answer all questions follow the instructions on the front cover of the answer booklet

past papers papers a levels business 9609 2023 gce - Jul 05 2023

web aug 13 2023 past papers papers a levels business 9609 2023 gce guide past papers of papers a levels business 9609 2023 cambridge o levels cambridge igcse cambridge int l as a levels caie october november 2023 session starts 0

cambridge international as a level business 9609 for examination - Mar 01 2023

web cambridge international as a level business 9609 for examination from 2023 what you need to know content will be available in print and digital resources this series has been written to support the cambridge international as a level business 9609 syllabus for examination from 2023

cambridge international as and a level business cambridge - Jun 23 2022

web it provides thorough examination support for all papers with exam style questions with each chapter and an extensive paper 3 style case study with each unit the student cd rom contains revision aids further questions and activities

cambridge international as a level gce guide - Nov 28 2022

web cambridge international as a level business 9609 31 paper 3 case study may june 2020 mark scheme maximum mark 100 published students did not sit exam papers in the june 2020 series due to the covid 19 global pandemic this mark scheme is published to support teachers and students and should be read together with the question paper