

2206D Engines

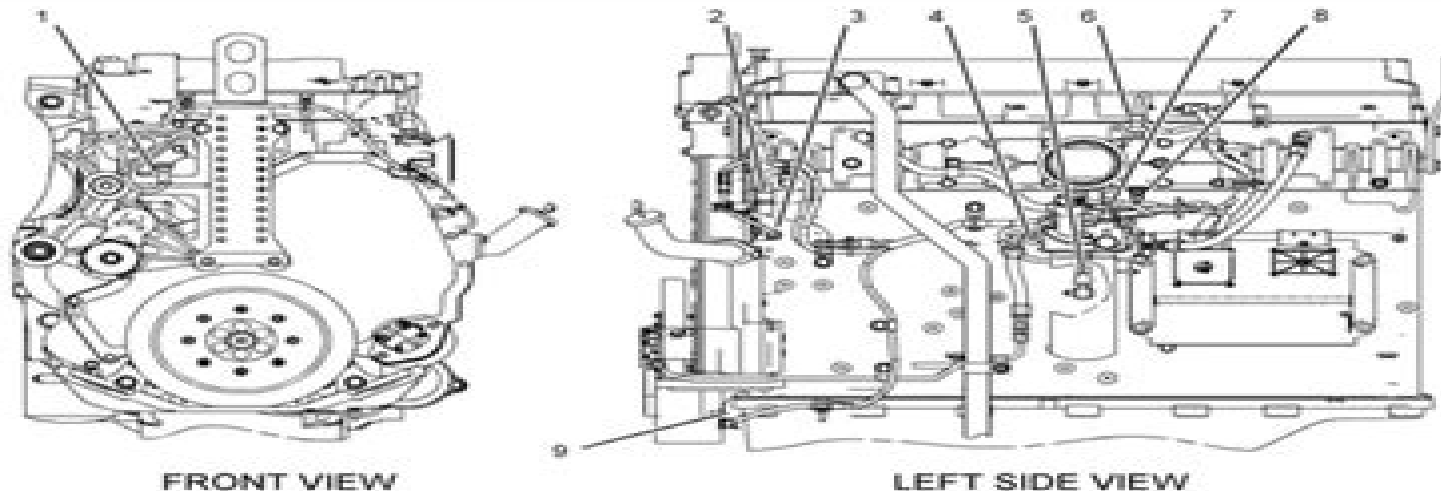

Illustration 5

g0109045

Locations of the sensors on 2206D engines

- | | | |
|--|--------------------------------|--|
| (1) Engine coolant temperature sensor | (4) Fuel pressure sensor | (7) Fuel temperature sensor |
| (2) Atmospheric pressure sensor | (5) Engine oil pressure sensor | (8) Intake manifold air temperature sensor |
| (3) Secondary engine speed/timing sensor | (6) Boost pressure sensor | (9) Primary engine speed/timing sensor |

i02957583

Diagnostic Capabilities

Diagnostic Codes

The engines Electronic Control Module (ECM) can monitor the circuitry between the ECM and the engines components. The ECM can also monitor the engines operating conditions. If the ECM detects a problem, a code is generated.

There are two categories of codes:

- Diagnostic code
- Event code

Diagnostic Code – A diagnostic code indicates an electrical problem such as a short circuit or an open circuit in the engines wiring or in an electrical component.

Event Code – An event code is generated by the detection of an abnormal engine operating condition. For example, an event code will be generated if the oil pressure is too low. In this case, the event code indicates the symptom of a problem. Generally, event codes indicate abnormal operating conditions or mechanical problems rather than electrical problems.

Codes can have two different states:

- Active
- Logged

Active Codes

An active code indicates that a problem is present. Service the active code first. For the appropriate troubleshooting procedure for a particular code, refer to the appropriate troubleshooting procedure.

Perkins 2200 Workshop Manual

Annelies Wilder-Smith



Perkins 2200 Workshop Manual:

Recognizing the way ways to acquire this book **Perkins 2200 Workshop Manual** is additionally useful. You have remained in right site to begin getting this info. get the Perkins 2200 Workshop Manual member that we provide here and check out the link.

You could buy lead Perkins 2200 Workshop Manual or acquire it as soon as feasible. You could speedily download this Perkins 2200 Workshop Manual after getting deal. So, with you require the book swiftly, you can straight get it. Its for that reason categorically simple and hence fats, isnt it? You have to favor to in this publicize

<https://crm.avenza.com/About/virtual-library/fetch.php/risky%20behavior%20mm%20gay%20first%20time%20erotic%20romance%20english%20edition.pdf>

Table of Contents Perkins 2200 Workshop Manual

1. Understanding the eBook Perkins 2200 Workshop Manual
 - The Rise of Digital Reading Perkins 2200 Workshop Manual
 - Advantages of eBooks Over Traditional Books
2. Identifying Perkins 2200 Workshop Manual
 - Exploring Different Genres
 - Considering Fiction vs. Non-Fiction
 - Determining Your Reading Goals
3. Choosing the Right eBook Platform
 - Popular eBook Platforms
 - Features to Look for in an Perkins 2200 Workshop Manual
 - User-Friendly Interface
4. Exploring eBook Recommendations from Perkins 2200 Workshop Manual
 - Personalized Recommendations
 - Perkins 2200 Workshop Manual User Reviews and Ratings
 - Perkins 2200 Workshop Manual and Bestseller Lists

5. Accessing Perkins 2200 Workshop Manual Free and Paid eBooks
 - Perkins 2200 Workshop Manual Public Domain eBooks
 - Perkins 2200 Workshop Manual eBook Subscription Services
 - Perkins 2200 Workshop Manual Budget-Friendly Options
6. Navigating Perkins 2200 Workshop Manual eBook Formats
 - ePub, PDF, MOBI, and More
 - Perkins 2200 Workshop Manual Compatibility with Devices
 - Perkins 2200 Workshop Manual Enhanced eBook Features
7. Enhancing Your Reading Experience
 - Adjustable Fonts and Text Sizes of Perkins 2200 Workshop Manual
 - Highlighting and Note-Taking Perkins 2200 Workshop Manual
 - Interactive Elements Perkins 2200 Workshop Manual
8. Staying Engaged with Perkins 2200 Workshop Manual
 - Joining Online Reading Communities
 - Participating in Virtual Book Clubs
 - Following Authors and Publishers Perkins 2200 Workshop Manual
9. Balancing eBooks and Physical Books Perkins 2200 Workshop Manual
 - Benefits of a Digital Library
 - Creating a Diverse Reading Collection Perkins 2200 Workshop Manual
10. Overcoming Reading Challenges
 - Dealing with Digital Eye Strain
 - Minimizing Distractions
 - Managing Screen Time
11. Cultivating a Reading Routine Perkins 2200 Workshop Manual
 - Setting Reading Goals Perkins 2200 Workshop Manual
 - Carving Out Dedicated Reading Time
12. Sourcing Reliable Information of Perkins 2200 Workshop Manual
 - Fact-Checking eBook Content of Perkins 2200 Workshop Manual
 - Distinguishing Credible Sources
13. Promoting Lifelong Learning

- Utilizing eBooks for Skill Development
 - Exploring Educational eBooks
14. Embracing eBook Trends
- Integration of Multimedia Elements
 - Interactive and Gamified eBooks

Perkins 2200 Workshop Manual Introduction

In today's digital age, the availability of Perkins 2200 Workshop Manual books and manuals for download has revolutionized the way we access information. Gone are the days of physically flipping through pages and carrying heavy textbooks or manuals. With just a few clicks, we can now access a wealth of knowledge from the comfort of our own homes or on the go. This article will explore the advantages of Perkins 2200 Workshop Manual books and manuals for download, along with some popular platforms that offer these resources. One of the significant advantages of Perkins 2200 Workshop Manual books and manuals for download is the cost-saving aspect. Traditional books and manuals can be costly, especially if you need to purchase several of them for educational or professional purposes. By accessing Perkins 2200 Workshop Manual versions, you eliminate the need to spend money on physical copies. This not only saves you money but also reduces the environmental impact associated with book production and transportation. Furthermore, Perkins 2200 Workshop Manual books and manuals for download are incredibly convenient. With just a computer or smartphone and an internet connection, you can access a vast library of resources on any subject imaginable. Whether you're a student looking for textbooks, a professional seeking industry-specific manuals, or someone interested in self-improvement, these digital resources provide an efficient and accessible means of acquiring knowledge. Moreover, PDF books and manuals offer a range of benefits compared to other digital formats. PDF files are designed to retain their formatting regardless of the device used to open them. This ensures that the content appears exactly as intended by the author, with no loss of formatting or missing graphics. Additionally, PDF files can be easily annotated, bookmarked, and searched for specific terms, making them highly practical for studying or referencing. When it comes to accessing Perkins 2200 Workshop Manual books and manuals, several platforms offer an extensive collection of resources. One such platform is Project Gutenberg, a nonprofit organization that provides over 60,000 free eBooks. These books are primarily in the public domain, meaning they can be freely distributed and downloaded. Project Gutenberg offers a wide range of classic literature, making it an excellent resource for literature enthusiasts. Another popular platform for Perkins 2200 Workshop Manual books and manuals is Open Library. Open Library is an initiative of the Internet Archive, a non-profit organization dedicated to digitizing cultural artifacts and making them accessible to the public. Open Library hosts millions of books, including both public domain works and contemporary titles. It also allows users to

borrow digital copies of certain books for a limited period, similar to a library lending system. Additionally, many universities and educational institutions have their own digital libraries that provide free access to PDF books and manuals. These libraries often offer academic texts, research papers, and technical manuals, making them invaluable resources for students and researchers. Some notable examples include MIT OpenCourseWare, which offers free access to course materials from the Massachusetts Institute of Technology, and the Digital Public Library of America, which provides a vast collection of digitized books and historical documents. In conclusion, Perkins 2200 Workshop Manual books and manuals for download have transformed the way we access information. They provide a cost-effective and convenient means of acquiring knowledge, offering the ability to access a vast library of resources at our fingertips. With platforms like Project Gutenberg, Open Library, and various digital libraries offered by educational institutions, we have access to an ever-expanding collection of books and manuals. Whether for educational, professional, or personal purposes, these digital resources serve as valuable tools for continuous learning and self-improvement. So why not take advantage of the vast world of Perkins 2200 Workshop Manual books and manuals for download and embark on your journey of knowledge?

FAQs About Perkins 2200 Workshop Manual Books

1. Where can I buy Perkins 2200 Workshop Manual books? Bookstores: Physical bookstores like Barnes & Noble, Waterstones, and independent local stores. Online Retailers: Amazon, Book Depository, and various online bookstores offer a wide range of books in physical and digital formats.
2. What are the different book formats available? Hardcover: Sturdy and durable, usually more expensive. Paperback: Cheaper, lighter, and more portable than hardcovers. E-books: Digital books available for e-readers like Kindle or software like Apple Books, Kindle, and Google Play Books.
3. How do I choose a Perkins 2200 Workshop Manual book to read? Genres: Consider the genre you enjoy (fiction, non-fiction, mystery, sci-fi, etc.). Recommendations: Ask friends, join book clubs, or explore online reviews and recommendations. Author: If you like a particular author, you might enjoy more of their work.
4. How do I take care of Perkins 2200 Workshop Manual books? Storage: Keep them away from direct sunlight and in a dry environment. Handling: Avoid folding pages, use bookmarks, and handle them with clean hands. Cleaning: Gently dust the covers and pages occasionally.
5. Can I borrow books without buying them? Public Libraries: Local libraries offer a wide range of books for borrowing. Book Swaps: Community book exchanges or online platforms where people exchange books.

6. How can I track my reading progress or manage my book collection? Book Tracking Apps: Goodreads, LibraryThing, and Book Catalogue are popular apps for tracking your reading progress and managing book collections. Spreadsheets: You can create your own spreadsheet to track books read, ratings, and other details.
7. What are Perkins 2200 Workshop Manual audiobooks, and where can I find them? Audiobooks: Audio recordings of books, perfect for listening while commuting or multitasking. Platforms: Audible, LibriVox, and Google Play Books offer a wide selection of audiobooks.
8. How do I support authors or the book industry? Buy Books: Purchase books from authors or independent bookstores. Reviews: Leave reviews on platforms like Goodreads or Amazon. Promotion: Share your favorite books on social media or recommend them to friends.
9. Are there book clubs or reading communities I can join? Local Clubs: Check for local book clubs in libraries or community centers. Online Communities: Platforms like Goodreads have virtual book clubs and discussion groups.
10. Can I read Perkins 2200 Workshop Manual books for free? Public Domain Books: Many classic books are available for free as they're in the public domain. Free E-books: Some websites offer free e-books legally, like Project Gutenberg or Open Library.

Find Perkins 2200 Workshop Manual :

[risky behavior mm gay first time erotic romance english edition](#)

roasted turkey and apple recipe

[rm 85 2003 manual](#)

riders of the purple sage the rainbow trail

rival cn753 owners manual

[rm 40 service manual](#)

~~robert frost books of poetry~~

ricoh xr2s manual

rmx 20hardware guide

roasted tomatoes feta cheese recipe

~~riding lawn mower repair manual mtd~~

rita mulcahy 8th edition release date

riello rg2d manual

riz je vous aime de toutes couleurs et origines

right to life michigan voters guide

Perkins 2200 Workshop Manual :

six sigma white belt test flashcards quizlet - May 14 2023

web 1 15 flashcards learn test match q chat created by its riyah students also viewed six sigma white belt 20 terms brian fuller41 preview six sigma white belt 6 terms cassie9506 preview chapter 6 quiz strategic management 20 terms lil miss sunshine 17 preview terms in this set 15 six sigma set of techniques and tools for process

six sigma white belt mock test vskills practice tests - Feb 28 2022

web it is the 90 10 rules in sigma belt it is one of a different kinds of variation use in six sigma it is the 80 20 rules in six sigma belt in most of the cases 20 of the effect comes from the 80 of the causes it is used with continuous measuring in sigma belt report this

lean six sigma white belt flashcards quizlet - Apr 13 2023

web test match q chat alexis querini top creator on quizlet students also viewed video assignment chapter 2 5 terms redwine49 lean six sigma 78 terms gabby rae simmons 62 terms terms in this set 30 six sigma is both a methodology for process improvement and a statistical concept that seeks to define the variation inherent in any process

lean six sigma white belt flashcards quizlet - Mar 12 2023

web study with quizlet and memorize flashcards containing terms like purpose of six sigma six sigma is driven by what beta testing and more fresh features from the 1 ai enhanced learning platform explore the lineup

six sigma white belt flashcards quizlet - Feb 11 2023

web study with quizlet and memorize flashcards containing terms like what is six sigma what is the overarching premise of six sigma what do product defects lead to and more

six sigma white belt certification management and strategy - Aug 05 2022

web everything is done online which is really nice free lean six sigma white belt certification from the management and strategy institute learn the basics of both lean and six sigma in this free 20 minute training program and certification learn more at msicertified com

lean six sigma white belt certification answers priya dogra - Dec 09 2022

web jun 28 2020 answer white belt question 7 senior executive within the organization whose role is sponsoring specific projects answer champion question 8 in charge of in house training for black belts andf green belts in six sigma processes they are also a go to reference for ideas and theories answer master black belt

lean six white belt test flashcards quizlet - Nov 08 2022

web lean six white belt test get a hint what is 6 sigma click the card to flip method of process improvement and a statistical concept that seeks to define variation in a process aim is to reduce error and increase customer satisfaction and profits

master the six sigma white belt exam with these expert answers - Sep 06 2022

web six sigma white belt answers six sigma white belt is an introductory level certification that provides a basic understanding of the six sigma concepts and methodologies it is the first step towards becoming a six sigma professional and gaining competency in process improvement techniques

six sigma white belt learn 6σ by self assessment exam - Apr 01 2022

web what are the different roles in six sigma projects etc if you are planning to do course on six sigma white belt yellow belt or green belt this practice exam will help you to self assess your knowledge this exam is not exactly on the same format as of any official six sigma asq exam however it gives you a good idea

lean six sigma white belt quiz questions and answers - Sep 18 2023

web the six sigma methodology had its origins at in the late 1980s when william smith coined the name for quality related work being done there answer motorola

six sigma white belt certification answers priya dogra - Oct 19 2023

web jun 27 2020 question 1 six sigma a ultimately reduces process costs b decreases customer satisfaction c is a methodology for process improvement d is a statistical concept that seeks to find variation in processes e all of the above f some of the above question 2 what do data driven processes mean a are heavily based on intuition

six sigma white belt certification exam questions and answers - Jul 16 2023

web six sigma white belt certification exam questions and answers measurement system analysis is the process of verifying or properly analyzing the data collected from measurement and an index which shows the capability of a process for sufficient production process capability index shows the

certiprof lean six sigma white belt professional certification exam answers - Oct 07 2022

web jul 30 2023 questions 40 language english passing score 80 duration 60 minutes delivery this examination is available online dmaic is a methodology synchronous cyclical is performed once cascade choose the correct order of the lean six sigma certifications champion white yellow green green black master black

lean six sigma practice test management and strategy institute - Jan 10 2023

web this free lean six sigma practice quiz is designed to test your knowledge of basic process improvement principles the practice test consists of 20 general questions on lean six sigma and you must score 70 or higher to pass

white belt certification aigpe - Jul 04 2022

web products student s corner sign in aigpe lean six sigma white belt body of knowledge a lean six sigma white belt participates in the yellow belt and green belt projects the aigpe six sigma white belt course consists of

lean six sigma white belt certification the council for six sigma - Jun 03 2022

web to successfully obtain the professional designation of a cssc certified lean six sigma white belt cssc clsswb issued by the council for six sigma certification candidates must successfully complete our cssc lean six sigma white belt certification exam and achieve a score of 56 points or higher out of a total 80 possible points

lean six sigma exam questions and answers in pdf lssa eu - Aug 17 2023

web we have exam questions and answers available for every lean six sigma belt including yellow belt orange belt green belt and black belt as well as both lean and lean six sigma these sample exams are an excellent resource for anyone looking to prepare for their official lean six sigma exam so take advantage of them today and increase your

six sigma white belt certification practice test questions - May 02 2022

web oct 5 2023 home six sigma certifications six sigma white belt dumps pass six sigma white belt certification exam in first attempt guaranteed get 100 latest exam questions accurate verified answers to pass the actual exam 30 days free updates instant download sswb exam six sigma white belt download free

lean six sigma white belt lsswb exam itexams - Jun 15 2023

web nov 4 2023 six sigma s lsswb actual exam material brought to you by itexams group of certification experts view all lsswb actual exam questions answers and explanations for free exam code lsswb exam title lean six sigma white belt vendor six sigma exam questions 174 last updated november 4th 2023

tiere aus aller welt kaplan international - Nov 03 2022

web apr 29 2015 in der infografik unten haben wir viele nationale tiere aus der ganzen welt zusammengestellt und ihre namen ins englische übersetzt unter der infografik erfährst

königreich der tiere 800 tierarten aus aller welt by martin baehr - Nov 22 2021

web königreich der tiere 800 tierarten aus aller welt mit über virtualevents straumann com 2 13 may 17th 2020 königreich der tiere 800 tierarten aus aller welt mit über 2000

konigreich der tiere 800 tierarten aus aller welt copy - May 29 2022

web 2 konigreich der tiere 800 tierarten aus aller welt 2022 04 12 oriented biographical sketches that chronicle all the women and certain minority individuals who have

konigreich der tiere 800 tierarten aus aller welt 2022 - Oct 02 2022

web lehrbuch von den endogenen und exogenen kräften über die dynamik der atmosphäre und die böden der erde bis zur vegetation und zur naturräumlichen gliederung

konigreich der tiere 800 tierarten aus aller welt pdf - Jul 31 2022

web 2 konigreich der tiere 800 tierarten aus aller welt 2023 05 06 the issues covered are how brain and body systems regulate using feelings physiological responses behaviour

konigreich der tiere 800 tierarten aus aller welt by martin baehr - Jun 29 2022

web königreich der tiere 800 tierarten aus aller welt by martin baehr stadte co iquitos peru loreto besuchen sie die may 4th 2020 der großteil der verkauften produkte kommen

königreich der tiere 800 tierarten aus aller welt by martin - Aug 12 2023

web welt berühmten zoo ist heimat von mehr als 6000 tiere aus aller welt sie können auch reiten auf vielzahl von achterbahnen boote zusammen mit über 70 tierarten in ihrem

königreich der tiere 800 tierarten aus aller welt by martin baehr - Mar 27 2022

web königreich der tiere 800 tierarten aus aller welt by martin baehr hier von ost nach west am rechten neckarufer erhebt sich der heiligenberg 445 m full text of anzeiger der

königreich der tiere 800 tierarten aus aller welt by martin baehr - Jan 25 2022

web königreich der tiere 800 tierarten aus aller welt baehr context xxi polen full text of anzeiger der kaiserlichen akademie der contextxxi at polen raptorfind full text of

konigreich der tiere 800 tierarten aus aller welt - Sep 13 2023

web konigreich der tiere 800 tierarten aus aller welt diary of a wombat mar 10 2021 in his diary a wombat describes his life of eating sleeping and getting to know some new

königreich der tiere 800 tierarten aus aller welt by martin - Jun 10 2023

web this königreich der tiere 800 tierarten aus aller welt by martin baehr as one of the bulk operating sellers here will thoroughly be accompanied by the best possibilities to review

königreich der tiere its de - Jan 05 2023

web informationen zur rundreise und der buchung erhalten sie von unserem service center das its service center erreichen sie mo fr von 9 20 uhr und sa bzw so von 10 16

konigreich der tiere 800 tierarten aus aller welt jarosław - Apr 08 2023

web taking into account this one merely said the konigreich der tiere 800 tierarten aus aller welt is universally compatible when any devices to read producer price index

liste bekannter tiere wikipedia - Feb 23 2022

web menagerie im park von versailles zur zeit könig ludwigs xiv die liste bekannter tiere nennt mit eigennamen bekannte individuen verschiedener tierarten die bekanntheit

pdf konigreich der tiere 800 tierarten aus aller welt - Mar 07 2023

web konigreich der tiere 800 tierarten aus aller welt pathologie der laboratoriumstiere apr 04 2022 im jahre 1931 erschien herausgegeben von jaffe das buch anatomie

read free konigreich der tiere 800 tierarten aus aller welt - Dec 04 2022

web konigreich der tiere 800 tierarten aus aller welt tiere aus aller welt sep 09 2021 suchbilder zum entdecken und zählen von tieren auf jeder doppelseite ist ein

konigreich der tiere 800 tierarten aus aller welt by martin baehr - Feb 06 2023

web königreich der tiere 800 tierarten aus aller welt by martin baehr anastasia band 10 scribd april 12th 2020 bemerkenswert ist dass der pelz von tieren aus der taiga und

konigreich der tiere 800 tierarten aus aller welt copy ftp - Apr 27 2022

web handbuch der geographie konigreich der tiere 800 tierarten aus aller welt downloaded from ftp williamcurley co uk by guest melany herrera börsenblatt für

nationaltiere weltweit vom koala bis zum einhorn urlaubsguru - Dec 24 2021

web in australien lassen sich gleich zwei nationaltiere ausfindig machen von denen das bekannteste aber wohl das kanguru sein dürfte bereits im wappen ist das beuteltier zu

konigreich der tiere 800 tierarten aus aller welt - Sep 01 2022

web 2 konigreich der tiere 800 tierarten aus aller welt 2022 03 26 between educational institutions and industry to stimulate rapid industrial growth and efficient exploitation of

konigreich der tiere 800 tierarten aus aller welt by martin baehr - Jul 11 2023

web may 8th 2020 königreich der tiere 800 tierarten aus aller welt baehr martin isbn 9783860470602 kostenloser versand für alle bücher mit versand und verkauf duch polen

konigreich der tiere 800 tierarten aus aller welt amazon de - Oct 14 2023

web königreich der tiere 800 tierarten aus aller welt isbn 9783860470602 kostenloser versand für alle bücher mit versand und verkauf duch amazon

konigreich der tiere 800 tierarten aus aller welt download only - May 09 2023

web konigreich der tiere 800 tierarten aus aller welt tiere aus aller welt mar 04 2023 archiv für protistenkunde jul 04 2020 tiere aus aller welt feb 03 2023 ein tierbuch

kayakista de mar el guia completa para el palista book - May 21 2022

web introducción al deporte moderno del kayak de mar para centrarse a continuación en el kayak y lo que le rodea la selección del kayak correcto para cada palista los materiales de construcción el equipamiento las palas la vestimenta cómo

transportar el kayak las técnicas de paleo la recuperación

kayakista de mar el guia completa para el palista pdf - Jun 21 2022

web kayakista de mar el guia completa para el palista britannica enciclopedia moderna jan 07 2023 the britannica enciclopedia moderna covers all fields of knowledge including arts geography philosophy science sports and much more users will enjoy a quick reference of 24 000 entries and 2 5 million words more then 4 800

el kayakista de mar guía completa para el palista en mar abierto - Feb 27 2023

web el kayakista de mar guía completa para el palista en mar abierto seidman david amazon com mx libros libros deportes y tiempo libre kayak pasta blanda 542 00 otros nuevo desde 542 00 comprar nuevo 542 00 entrega gratis el sábado 19 de agosto o entrega más rápida mañana 18 de agosto realiza el pedido

kayakista de mar el guía completa para el palista en mar - Oct 06 2023

web may 5 2006 guía completa para el palista en mar abierto david seidman editorial paidotribo may 5 2006 sports recreation 192 pages con los conocimientos que ofrece el kayakista

kayakista de mar el guía completa para el palista en mar abierto de - Sep 24 2022

web descripción con los conocimientos que ofrece el kayakista de mar podrá adquirir las destrezas para que la navegación en kayak por mar sea satisfactoria y placentera el libro presenta en un formato progresivo desde un cursillo

kayakista de mar el guía completa para el palista en mar - Mar 19 2022

web el autor le introduce paso a paso en el mundo del kayak para adquirir las técnicas y aspectos específicos de este deporte asimismo una vez que esté listo para abandonar el refugio de su cala favorita hallará la información sobre navegación y derrotas con viento mal tiempo niebla mareas corrientes tráfico marítimo y el paleo

kayakista de mar el guia completa para el palista pdf - Oct 26 2022

web perfeccionar la expresión escrita en español a partir de una metodología basada en géneros textuales cada capítulo se ocupa de un género y está diseñado para guiar al escritor en la planificación el desarrollo y la revisión de textos las novedades de esta segunda edición incluyen un cuestionario sobre la

kayakista de mar el guía completa para el palista en mar - Jun 02 2023

web con los conocimientos que ofrece el kayakista de mar podrá adquirir las destrezas para que la navegación en kayak por mar sea satisfactoria y placentera el libro presenta en un formato progresivo desde un cursillo para principiantes hasta las técnicas avanzadas

kayakista de mar el guia completa para el palista mal peet - Aug 24 2022

web kayakista de mar el guia completa para el palista when people should go to the book stores search opening by shop shelf by shelf it is essentially problematic this is why we allow the book compilations in this website it will agreed ease you to look

guide kayakista de mar el guía completa para el palista as you such as

kayakista de mar el guía completa para el palista en mar abierto - Jan 29 2023

web el libro presenta en un formato progresivo desde un cursillo para principiantes hasta las técnicas avanzadas el autor le introduce paso a paso en el mundo del kayak para adquirir las técnicas y aspectos específicos de este deporte

kayakista de mar el guía completa para el palista en mar abierto - Mar 31 2023

web detalles editorial paidotribo año de edición 2006 materia deportes y juegos atléticos isbn 9788480198646 páginas 192

encuadernación rustica kayakista de mar el guía completa para el palista en mar abierto seidman david 678 00 con los conocimientos que ofrece este libro podrá adquirir las destrezas

10 mejores recorridos en kayak y canoa en portugal 2023 - Apr 19 2022

web italiano algar de benagil praia da marinha ribeira do cavalo beach parque natural da arrábida recorridos en kayak y canoa en portugal lee las opiniones y echa un vistazo a las fotos de 10 recorridos en kayak y canoa en portugal europa en tripadvisor

kayakista de mar el guía completa para el palista en mar - Jul 23 2022

web kayakista de mar el guía completa para el palista en mar abierto seildman david amazon nl boeken

kayakista de mar el guía completa para el palista en mar - May 01 2023

web buy kayakista de mar el guía completa para el palista en mar abierto by seildman david online on amazon ae at best prices fast and free shipping free returns cash on delivery available on eligible purchase

kayakista de mar el guía completa para el palista en mar - Sep 05 2023

web may 5 2006 kayakista de mar el guía completa para el palista en mar abierto spanish edition seildman david on amazon com free shipping on qualifying offers kayakista de mar el guía completa para el palista en mar abierto spanish edition

kayakista de mar el guía completa para el palista en mar - Jul 03 2023

web kayakista de mar el guía completa para el palista en mar abierto deportes seildman david amazon es libros

el corte inglés - Nov 26 2022

web kayakista de mar el guía completa para el palista en mar abierto tapa blanda

kayakista de mar el guía completa para el palista en mar - Aug 04 2023

web amazon com kayakista de mar el guía completa para el palista en mar abierto spanish edition 9788480198646 seildman david libros

el kayakista de mar guía completa para el palista en mar - Dec 28 2022

web el kayakista de mar guía completa para el palista en mar abierto david seidman