

ENGINE

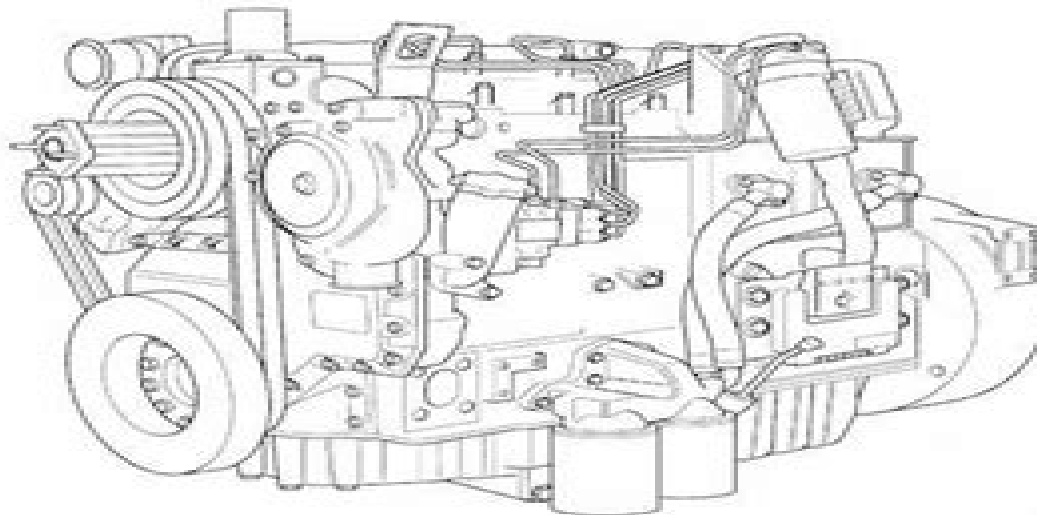

SERVICE MANUAL

Perkins®
1100 Series 6-Cylinder Diesel Engine



Perkins 1100 Service Manual

Raffaela Di Napoli



Perkins 1100 Service Manual:

Decoding **Perkins 1100 Service Manual**: Revealing the Captivating Potential of Verbal Expression

In a period characterized by interconnectedness and an insatiable thirst for knowledge, the captivating potential of verbal expression has emerged as a formidable force. Its ability to evoke sentiments, stimulate introspection, and incite profound transformations is genuinely awe-inspiring. Within the pages of "**Perkins 1100 Service Manual**," a mesmerizing literary creation penned with a celebrated wordsmith, readers embark on an enlightening odyssey, unraveling the intricate significance of language and its enduring affect our lives. In this appraisal, we shall explore the book is central themes, evaluate its distinctive writing style, and gauge its pervasive influence on the hearts and minds of its readership.

https://crm.avenza.com/About/uploaded-files/Documents/peachtree_study_guide.pdf

Table of Contents Perkins 1100 Service Manual

1. Understanding the eBook Perkins 1100 Service Manual
 - The Rise of Digital Reading Perkins 1100 Service Manual
 - Advantages of eBooks Over Traditional Books
2. Identifying Perkins 1100 Service Manual
 - Exploring Different Genres
 - Considering Fiction vs. Non-Fiction
 - Determining Your Reading Goals
3. Choosing the Right eBook Platform
 - Popular eBook Platforms
 - Features to Look for in an Perkins 1100 Service Manual
 - User-Friendly Interface
4. Exploring eBook Recommendations from Perkins 1100 Service Manual
 - Personalized Recommendations
 - Perkins 1100 Service Manual User Reviews and Ratings
 - Perkins 1100 Service Manual and Bestseller Lists

5. Accessing Perkins 1100 Service Manual Free and Paid eBooks
 - Perkins 1100 Service Manual Public Domain eBooks
 - Perkins 1100 Service Manual eBook Subscription Services
 - Perkins 1100 Service Manual Budget-Friendly Options
6. Navigating Perkins 1100 Service Manual eBook Formats
 - ePub, PDF, MOBI, and More
 - Perkins 1100 Service Manual Compatibility with Devices
 - Perkins 1100 Service Manual Enhanced eBook Features
7. Enhancing Your Reading Experience
 - Adjustable Fonts and Text Sizes of Perkins 1100 Service Manual
 - Highlighting and Note-Taking Perkins 1100 Service Manual
 - Interactive Elements Perkins 1100 Service Manual
8. Staying Engaged with Perkins 1100 Service Manual
 - Joining Online Reading Communities
 - Participating in Virtual Book Clubs
 - Following Authors and Publishers Perkins 1100 Service Manual
9. Balancing eBooks and Physical Books Perkins 1100 Service Manual
 - Benefits of a Digital Library
 - Creating a Diverse Reading Collection Perkins 1100 Service Manual
10. Overcoming Reading Challenges
 - Dealing with Digital Eye Strain
 - Minimizing Distractions
 - Managing Screen Time
11. Cultivating a Reading Routine Perkins 1100 Service Manual
 - Setting Reading Goals Perkins 1100 Service Manual
 - Carving Out Dedicated Reading Time
12. Sourcing Reliable Information of Perkins 1100 Service Manual
 - Fact-Checking eBook Content of Perkins 1100 Service Manual
 - Distinguishing Credible Sources
13. Promoting Lifelong Learning

- Utilizing eBooks for Skill Development
 - Exploring Educational eBooks
14. Embracing eBook Trends
- Integration of Multimedia Elements
 - Interactive and Gamified eBooks

Perkins 1100 Service Manual Introduction

In the digital age, access to information has become easier than ever before. The ability to download Perkins 1100 Service Manual has revolutionized the way we consume written content. Whether you are a student looking for course material, an avid reader searching for your next favorite book, or a professional seeking research papers, the option to download Perkins 1100 Service Manual has opened up a world of possibilities. Downloading Perkins 1100 Service Manual provides numerous advantages over physical copies of books and documents. Firstly, it is incredibly convenient. Gone are the days of carrying around heavy textbooks or bulky folders filled with papers. With the click of a button, you can gain immediate access to valuable resources on any device. This convenience allows for efficient studying, researching, and reading on the go. Moreover, the cost-effective nature of downloading Perkins 1100 Service Manual has democratized knowledge. Traditional books and academic journals can be expensive, making it difficult for individuals with limited financial resources to access information. By offering free PDF downloads, publishers and authors are enabling a wider audience to benefit from their work. This inclusivity promotes equal opportunities for learning and personal growth. There are numerous websites and platforms where individuals can download Perkins 1100 Service Manual. These websites range from academic databases offering research papers and journals to online libraries with an expansive collection of books from various genres. Many authors and publishers also upload their work to specific websites, granting readers access to their content without any charge. These platforms not only provide access to existing literature but also serve as an excellent platform for undiscovered authors to share their work with the world. However, it is essential to be cautious while downloading Perkins 1100 Service Manual. Some websites may offer pirated or illegally obtained copies of copyrighted material. Engaging in such activities not only violates copyright laws but also undermines the efforts of authors, publishers, and researchers. To ensure ethical downloading, it is advisable to utilize reputable websites that prioritize the legal distribution of content. When downloading Perkins 1100 Service Manual, users should also consider the potential security risks associated with online platforms. Malicious actors may exploit vulnerabilities in unprotected websites to distribute malware or steal personal information. To protect themselves, individuals should ensure their devices have reliable antivirus software installed and validate the legitimacy of the websites they are downloading from. In conclusion, the ability to download Perkins 1100

Service Manual has transformed the way we access information. With the convenience, cost-effectiveness, and accessibility it offers, free PDF downloads have become a popular choice for students, researchers, and book lovers worldwide. However, it is crucial to engage in ethical downloading practices and prioritize personal security when utilizing online platforms. By doing so, individuals can make the most of the vast array of free PDF resources available and embark on a journey of continuous learning and intellectual growth.

FAQs About Perkins 1100 Service Manual Books

How do I know which eBook platform is the best for me? Finding the best eBook platform depends on your reading preferences and device compatibility. Research different platforms, read user reviews, and explore their features before making a choice. Are free eBooks of good quality? Yes, many reputable platforms offer high-quality free eBooks, including classics and public domain works. However, make sure to verify the source to ensure the eBook credibility. Can I read eBooks without an eReader? Absolutely! Most eBook platforms offer web-based readers or mobile apps that allow you to read eBooks on your computer, tablet, or smartphone. How do I avoid digital eye strain while reading eBooks? To prevent digital eye strain, take regular breaks, adjust the font size and background color, and ensure proper lighting while reading eBooks. What the advantage of interactive eBooks? Interactive eBooks incorporate multimedia elements, quizzes, and activities, enhancing the reader engagement and providing a more immersive learning experience. Perkins 1100 Service Manual is one of the best book in our library for free trial. We provide copy of Perkins 1100 Service Manual in digital format, so the resources that you find are reliable. There are also many Ebooks of related with Perkins 1100 Service Manual. Where to download Perkins 1100 Service Manual online for free? Are you looking for Perkins 1100 Service Manual PDF? This is definitely going to save you time and cash in something you should think about.

Find Perkins 1100 Service Manual :

peachtree study guide

pearson math investigation codes

pearson 4th grade study guide

peachtree 2011 quantum user manual

[pearson geometry chapters 9 cumulative review](#)

[pcm power relay](#)

pearson chemistry workbook sol prep answer key

~~pe basketball test middle school~~

peanut butter chocolate smoothie recipe

pearson 3 unit test

pearson geometry teacher edition test answers

~~pcb design tutorial in eagle~~

pearson mastering chemistry 11 homework answer key

peak 928 pikes peak in a porsche 928

~~pearson biology workbook answers chapter 7~~

Perkins 1100 Service Manual :

abeka product information science earth and space quiz book - Oct 21 2022

web overview complete your child s learning adventure with the resources found in the science earth and space teacher edition

abeka product information science earth and space teacher - Jun 16 2022

web abeka science abeka science middle high school levels abeka science grade 8 science earth and space student quiz book

abeka product information science earth and space - May 28 2023

web science earth and space answer key 8 beka book 17478 on amazon com free shipping on qualifying offers science earth and space answer key

science earth and space answer key christianbook com - Mar 14 2022

abeka product information science earth and space activity - Jul 18 2022

web this science earth and space activity book key accompanies the abeka science earth and space activity book this key gives you a copy of the student activity book with

grade 8 abeka - Feb 22 2023

web homeschool parent led customize your homeschooling with flexible options standardized testing simple standardized testing from your home or classroom school curriculum

science earth and space quiz key a beka book - Apr 26 2023

web about planets stars asteroids space travel and lots more while learning lots of interesting new words soar study skills apr 12 2021 soar study skills is a comprehensive

abeka product information science earth and space quiz key - Nov 09 2021

abeka grade 8 science curriculum christianbook com - Feb 10 2022

abeka product information science earth and space - Oct 01 2023

web test match q chat created by tnai147 name of textbook is science earth and space second edition abeka book set made january 19 2022 the answers have the pages

science earth and space student quiz book a beka book - Jan 12 2022

8th grade abeka science section review 7 3 flashcards quizlet - Aug 31 2023

web 318655 science earth and space quiz key 318698 science earth and space activity book with stem project resources 318701 science earth and space activity book key

science earth and space activity book key - Jul 30 2023

web 318604 grade 8th grade dimensions 8 x 10 binding bound pages 428 edition second returns normal terms proven textbooks teacher materials more affordable

science earth and space abeka answer key - Nov 21 2022

web 318655 science earth and space quiz key 18 45 318698 science earth and space activity book with stem project resources

science earth and space answer key 8 beka book - Dec 23 2022

web 318655 science earth and space quiz key 18 45 318698 science earth and space activity book with stem project resources

science earth and space grade 8 christianbook com - Apr 14 2022

web science earth and space quiz key share a newer version of this product is available see new version this item is discontinued please call us at 1 877 223 5226 for other

science earth and space cathyduffyreviews com - Mar 26 2023

web please call us at 1 877 223 5226 for other options login required engage your child lighten your load with master teachers bundle save this item is included in these

science earth and space quizzes key - Jan 24 2023

web 318655 science earth and space quiz key 18 45 318698 science earth and space activity book with stem project resources

abeka product information science earth and space activity - Dec 11 2021

abeka product information science earth and space teacher - May 16 2022

web this activity book gives your student companion exercises to enjoy with the chapter reviews from science earth and space engage your students with activities like colorful

abeka product information science earth and space answer key - Sep 19 2022

web abeka s science earth and space 2nd edition curriculum explores the fields of geology oceanography meteorology astronomy and environmental science from a christian

science earth and space digital teaching aids abeka - Aug 19 2022

web science earth and space answer key abeka 2019 other write a review in stock this product ships free to addresses in the us just select standard shipping at checkout

earth and space science revised abeka - Jun 28 2023

web science earth and space test key science earth and space quiz key science earth and space activity key science earth and space activity book with stem project

attitude psychology wikipedia - Jul 01 2023

web attitudes are an important part of how we perceive our behaviors and unique characteristics likewise attitudes can have a profound effect on a person s behavior an attitude can be a positive or negative evaluation of

module 5 attitudes principles of social psychology open text - Aug 02 2023

web they are the final piece to understanding how we think about ourselves and others this module will focus on what they are why they are important focusing on the predictive nature of attitudes and finally how our behavior can impact our attitudes

how can our attitudes change and influence behaviors - Oct 04 2023

web mar 11 2023 frequently asked questions in psychology an attitude refers to a set of emotions beliefs and behaviors toward a particular object person thing or event attitudes are often the result of experience or upbringing they can have a powerful influence over behavior and affect how people act in various situations

components of attitude abc model simply psychology - Sep 03 2023

web jun 13 2023 the abc model of attitudes also known as the tri component model is a framework in psychology that describes 3 components of attitudes eagly chaiken 1998 affective component this involves a person s feelings emotions about the attitude object

attitudes oxford research encyclopedia of psychology - Mar 29 2023

web the study of attitudes takes a central position in social psychology decades of research have demonstrated that attitudes are important for understanding how individuals perceive the world and how they behave one of the key aspects of attitudes is their cognitive affective and behavioral content

[attitude english meaning cambridge dictionary](#) - May 31 2023

web a feeling or opinion about something or someone attitude his attitude towards authority has often got him into trouble outlook i wish i could share your positive outlook on life

attitudes introduction to psychology lumen learning - Feb 25 2023

web define attitude and recognize how people s attitudes are internally changed through cognitive dissonance social psychologists have documented how the power of the situation can influence our behaviors now we turn to how the power of the situation can influence our attitudes and beliefs attitude is our evaluation of a person an idea or an

5 1 exploring attitudes principles of social psychology - Apr 29 2023

web strong attitudes are attitudes that are more cognitively accessible they come to mind quickly regularly and easily we can easily measure attitude strength by assessing how quickly our attitudes are activated when we are exposed to the attitude object

maxxer 50 90cc onroad zip 22 4 mb repair manuals english - Mar 07 2022

kymco maxxer 300 factory service repair manual meets all your information needs to repair or make some adjustments to your kymco maxxer 300 this manual is intended as a handy

kymco atv maxxer 300 250 service repair manual free pre - May 09 2022

congratulations on your purchase of the kymco atv kymco take pride in a worldwide reputation for quality in research design production and service for replacement parts and

[2005 maxxer 50 90cc service manual zip 22 4 mb repair](#) - Apr 08 2022

download 148 kymco scooter pdf manuals user manuals kymco scooter operating guides and service manuals sign in upload manuals brands kymco manuals scooter

kymco mxu 450i service manual pdf download - Jun 22 2023

this service manual describes the technical features and servicing procedures for the kymco atv 300 250 section 1 contains the precautions for all operations stated in this manual

kymco maxxer manuals kymco - Jul 23 2023

view and download kymco mxu 450i service manual online mxu 450i offroad vehicle pdf manual download

manuals kymco page 4 - Nov 03 2021

kymco maxxer 50 user manual manualmachine com - Feb 06 2022

2005 maxxer 50 90cc service manual zip maxxer300 250 pdf kymco mxer 125 150 pdf kymco mxu 300 parts list pdf kymco mxu 250 parts list pdf playboy playmate

kymco maxxer 400 manual pdf download - Sep 25 2023

kymco mongoose maxxer 300 online service manual the official 249 page kymco mongoose 250 300 and maxxer 250 300 atv online service manual features detailed

kymco user manuals download manualslib - Jul 11 2022

2005 maxxer 50 90cc service manual zip contains 11 pdf files to open this file use application winrar rarlab com download htm repair manuals english kymco

kymco mongoose maxxer 300 online service manual - Aug 24 2023

2005 maxxer 50 90cc service manual zip contains 11 pdf files repair manuals 22 4 mb english maxxer maxxer300 250 pdf kymco service manual maxxer 300 250

kymco service manual azmotors fr - May 21 2023

sep 21 2020 kymco maxxer mongoose 250 300 service manual wiring diagrams owners manual solopdf com 12 4k subscribers subscribe like share save 646 views 3 years ago english

kymco maxxer 375 atv online service manual - Jan 17 2023

view and download kymco maxer user manual online maxer scooter pdf manual download also for maxer foru

kymco maxer user manual pdf download manualslib - Oct 14 2022

view download of more than 358 kymco pdf user manuals service manuals operating guides scooter offroad vehicle user manuals operating guides specifications

kymco 300 maxxer manual manualmachine com - Jun 10 2022

kymco maxxer 50 repair manuals english 22 4 mb uživatelský manuála pro model maxxer 50 90cc eng

kymco scooter user manuals download manualslib - Jan 05 2022

kymco maxxer 250 300 atv full service repair manual - Dec 16 2022

kymco service manual maxxer 300 250 mongoose 300 250 to open this file use application adobe reader get adobe com uk reader repair manuals english kymco

kymco maxxer 300 2005 factory service repair manual - Nov 15 2022

description the cyclepedia press llc kymco maxxer 375 atv service manual features detailed photographs and wiring diagrams complete specifications with step by step

[kymco maxxer 375 owner s manual pdf](#) - Feb 18 2023

the kymco maxxer 300 2005 manual has detailed illustrations as well as step by step instructions and contains everything you need to repair rebuild refurbish or restore your atv

kymco mxu 450i and maxxer 450i atv online - Apr 20 2023

view and download kymco maxxer 375 owner s manual online maxxer 375 offroad vehicle pdf manual download also for mxu 375

kymco maxxer 300 factory service repair manual ps017107 - Dec 04 2021

kymco maxxer 375 atv service manual printed by cyclepedia - Aug 12 2022

kymco atv maxxer 300 250 service repair manual free pre ps030115 27 59 23 99 13 rated 5 out of 5 based on 11 customer ratings 11 customer reviews add to cart sku

kymco maxxer mongoose 250 300 service manual youtube - Mar 19 2023

service repair workshop manual available for instant to your computer tablet or smart phone this professional manual covers all repairs servicing and troubleshooting pro kymco

maxxer300 250 pdf 9 8 mb repair manuals english en - Sep 13 2022

kymco 300 maxxer manual kymco manual download kymco dealers on kymcolux com 300 maxxer us road approved reverse technical